



# THE STING

www.thesting.org



April 28, 2004

SOUTHERN POLYTECHNIC STATE UNIVERSITY

Volume 58, Edition 9

## QUICK NEWS



Socials at School are Banned - Kenny tells you about the switching to new student numbers (pg 2).

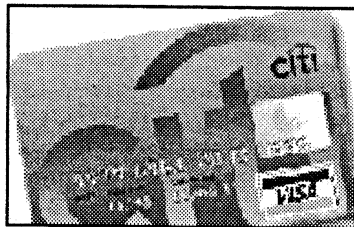

Credit Card Fraud - Officer tarcan tells you why you shouldn't fill out the CitiBank forms for free stuff (pg 3).

## QUICK FEATURES



Anonymous X's gives the "worst review ever" for Kill Bill 2 review. (pg 14).

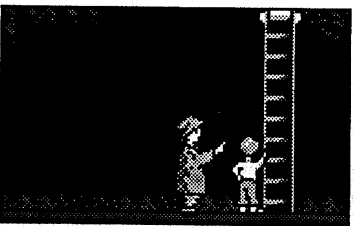

Home Alone 2 scores low and creepy for Sting critic Deven Gallo (pg 12).



Tom Green's hentai review - sex jello advice for all (pg 15).

## QUICK OPINION

Mom and Pop's Student Housing - what housing has done wrong this time. (pg 5).

Letter to the Editor - Career and Counseling's response to criticism (pg 6).

Soapbox Farewell - the Editor-in-Chief's final words (pg 5).

Farewell to SPSU - Micah Rowland's thoughts. (pg 5).

Section	Page
News	1
Opinion	5
Sports	9
Organizations	10
Entertainment	11

## Professor with Bought Degree

Karen Asay

An anonymous tip to The Sting recently led to the discovery that Industrial Engineering Professor James E. McKee's J.D. degree is from a diploma mill. McKee has an A.A.T. from Gwinnett Technical Institute, a B.B.A. and M.B.A from Georgia State University, and a J.D. from University of Devonshire, which is a diploma mill. According to the American Heritage Dictionary, a diploma mill is "an unaccredited institution of higher education that grants degrees without ensuring that students are properly qualified." This diploma mill is one of the biggest in the world. It has about 35 fake university names, University of Devonshire being one of them.

According to Patricia Carden, McKee was not given a raise, promotion, better benefits, or a bigger office, because of the degree. The IET department found out that McKee's J.D. was from a diploma mill two months after he got it. Carden commented that since the degree was a J.D. and didn't really have much to do with the department that McKee wouldn't get any benefits from the degree, except the title 'doctor.'

McKee had a heart attack Friday, April 16. He is now home and in stable condition, but is going to be out the rest of the semester. Ac-

ording to Carden, he is waiting to see if the medicine he was prescribed will work or if he will need surgery. McKee had originally planned on retiring after Spring of next year.

In related news, a second professor at SPSU was discovered to have degree from an unaccredited institution. "Dr." John Mench of the Construction Department has a Ph.D. in Business Administration from California Coast University. CCU has since dropped this degree as it seeks accreditation. California Coast is not currently accredited by any accrediting body of the Council on Higher Education Accreditation. Mench was hired by SPSU in August of 2001 and is

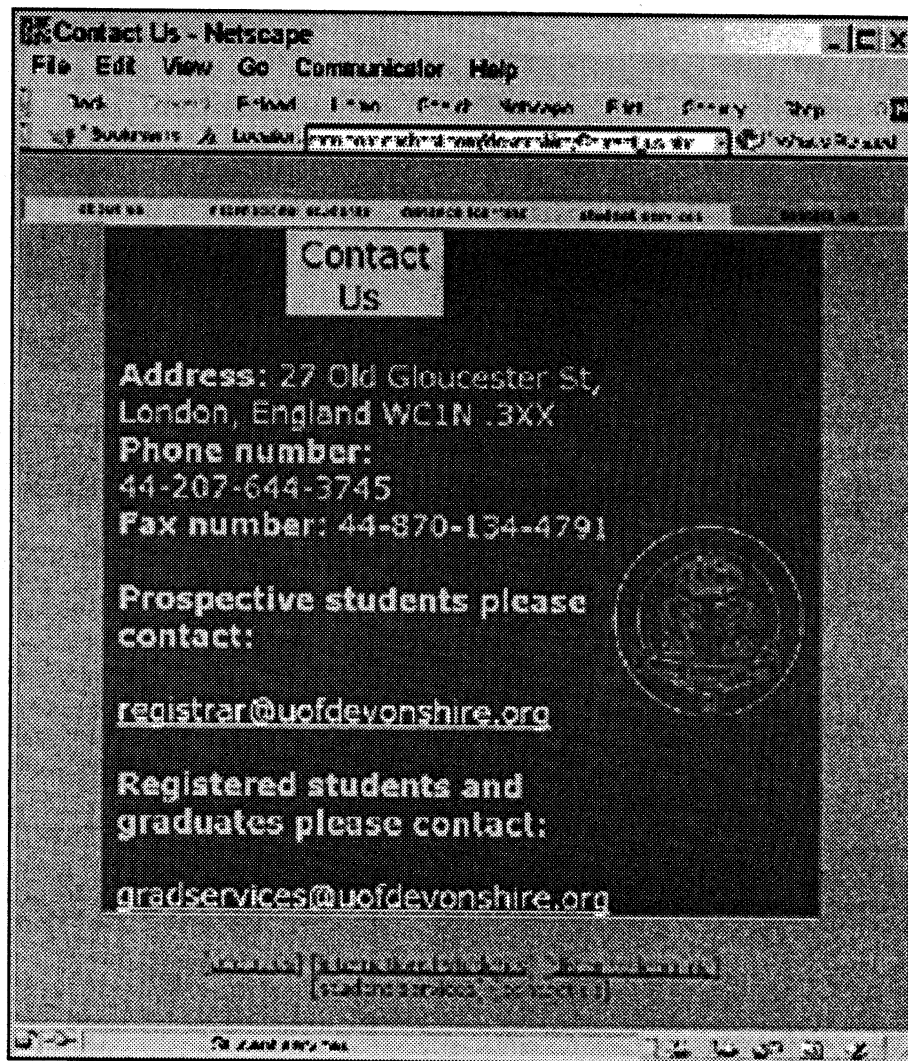

contracted to teach here through the 2004-2005 school year. Mench was contacted by The Sting, but was unavailable for comment.

## Student Hired by NASA

TONY PEREZ

The staff at *The Sting* would like to recognize and congratulate a young and brilliant student who, at this semester's graduation, will be walking across the stage and into the foothold of the world's future—NASA. Sandra Valencia, a senior physics major at Southern Poly, has accepted a position with one of NASA's facilities. She will be a Support Scientist in charge of deployment of equipment as part of

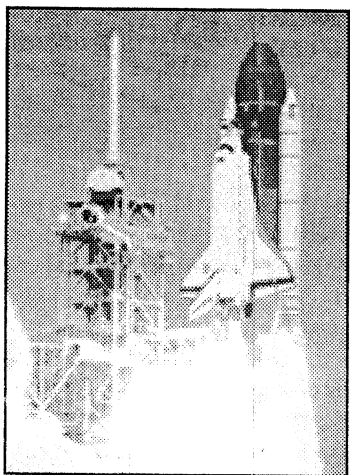

the Micro-Pulse Lidar Network (MPLNET). She has already been working for them on an internship and due to her outstanding perfor-

Continued on Page 2

## Confidential Student Files Left Out in the Cold

KENNY WHITE

Recently, while nosing around the campus, The Sting discovered numerous student files, containing privileged student information. These files were found outside the schools very own administration building. There were at least 100 full student records recovered. They range, for the most part, from the years 89-91. The files were for people with last names starting with "B" and a few with "C". They include everything the school keeps on all students: applications, marriage licenses (for change of name), Official school transcripts, academic hardship forms and medical records.

The forms filled out on this campus often include student addresses, SSNs, and phone numbers. Steve Hamrick, the Registrar and Assistant to the VPAA, outlined the procedure for handling these documents.

According to Hamrick, the school keeps your records on computer and on paper. Hamrick assured that the computer files are secured well; although, he admitted that even those files have been breached in the past. The paper files are kept in a secure, safe place in the administration building. The school keeps student information on file in the computer forever, but only keeps the paper records for 10 years from last

point of contact. Basically, this means they hold your records in case you come back in that period of 10 years.

Once a year, the Administration building empties out all the old files and sends them to plant ops.

The Sting contacted a few of the alumni whose current whereabouts were listed in the 2002 alumni directory. When asked for their comments on the disposal situation here on campus, Mr. Robert Bowen, who left Poly in 1989, said "That seems odd, sounds pretty dumb [to leave the papers in public access]." He also added "It's supposed to be a secure process since your SSN is with you your whole life". Another alumni who left in 1987, Mr. David Brooks, had this to say, "Sounds like a problem. They should be secure at all times".

I spoke with Mrs. Loretta Collier in the plant ops building who was brief in saying that the school has a

contract with a secure company that shreds the information sent to plant ops. All staff in the administration

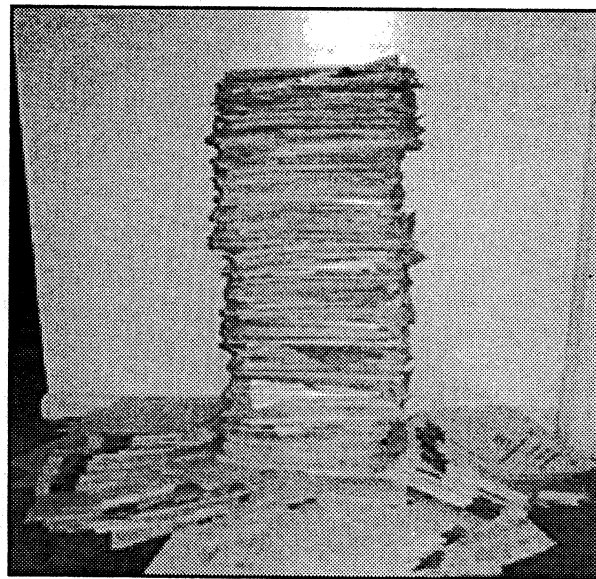

building have their own personal shredder in each office as well. Legally the only person allowed to view a student's grades is the student themselves. Even parents cannot get your records without written consent from the student. Many of these files are stamped in bright red "Do not permit any third party access to this document without written consent of student (20 U.S.C. 1232)". Another stamp in bright red on some files is the "Academic Advisement Only do not issued to student".

## Socials at School are Banned

KENNY WHITE

Starting this fall the Social Security Numbers will not be used on the campus as your student ID. An email sent out by Steve Hamrick to explained that The University System of Georgia has determined that using the social security number as a student identification number is no longer prudent and SPSU has begun the process of converting to a randomly generated student identification number. These numbers are being generated now and will be available shortly.

Your social security number will continue to work as an ID until October. In October, your social security number will cease to function as a student ID. Between now and then, you will receive your new number.

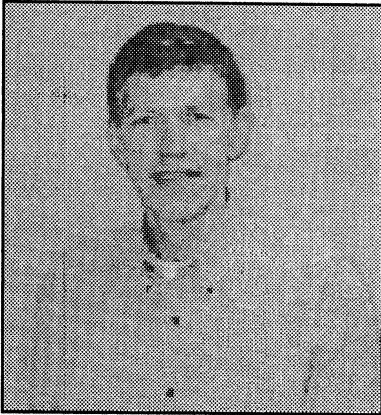

Steve Hamrick

You should begin using your new number as soon as you receive it, but remember if you lose your number or forget it; you can still access the system using your SSN until October. After October, your SSN will no longer work to get you into the Banner Student Information System and peripheral systems.

Mr. Hamrick informed The Sting that the switch to a new student ID number has been put off for a while because the SSN was/is used by all Financial Aid programs to identify students. He said that the switch was not completely voluntary; however, it was recommended as a "best practice" method. The school was given 3 years to make the jump from the SSN to the new system, but according

to Hamrick (SPSU) was waiting for Georgia Tech and Kennesaw State to learn from any mistakes that may occur. He added that in future financial aid/transcript situations the SSN would be added at the bottom as follows "XXX-XX-???" Meaning it would appear like credit card numbers to on receipts. This way the transcripts can still be matched to students, but the SSN stays secure.

As far as student IDs go, Mr. Hamrick isn't sure at this point what exactly will happen. One method the police department has suggested to him was just issuing new IDs with the new number encoded. It is likely that the old card will still work after the switch; however, the old cards would still be encoded with the SSN.

He reported that the numbers have been delayed a little while more, they should be issued in the next few weeks. The newly issued number will be your number at this school forever since it is not likely they will never have to use the same number again soon.

## Earth Day

KRYSTALYN NORTON

On April 22, 1970 two men made environmental history with the first "Earth Day" ever. Gaylord Nelson, founder, and Denis Hayes, coordinator, started Earth Day to express to the American people and politicians that environmental protection is a major issue. The founding of Earth Day helped America realize what we, as humans, were doing to our world. Many have forgotten, or just don't care, that environmental protection is still a major issue. The air we breathe, the water we drink, the life we live, still depends on our environment. There is no questioning that the earth is our provider and our home. Earth Day is a reminder that we need to be saving the planet everyday, in every way, and not destroying it.

The first twenty years Earth Day was celebrated only in the United States, but, in 1990, Denis Hayes organized the first international Earth Day. Two hundred million participants in one hundred, forty-one countries did their part to celebrate their love of the planet. Now the Earth Day Network, also started and headed by Hayes and Nelson, is the global network that organizes events and reminds the world that mother earth needs our help.

Endless problems have been caused by pollution, including many that are right here in Atlanta. For example, toxic mercury contamination of the Chattahoochee River making swimming and fishing unsafe, the rise of the percent of children getting asthma in the metropolitan area, the headache that you get when your stuck in a traffic jam on the interstate, and many others. Environmental needs stretch way

beyond the US and without the help of regular people the quality of life will continue to deteriorate along with the earth itself. So, I leave you with a reminder that Earth Day is not just April 22, but every day that you wake-up and breathe or eat or move or live.

There are endless ways that you can help. A few small things that you can do are use non-toxic cleaners (phosphate and chlorine free) instead use dish soap, a warm rag, and baking soda to clean counter tops and other surfaces, reduce the use of disposable things like paper plates and paper towels, reuse or donate things to thrift stores rather than throwing them away, recycle whenever possible, support organic ways to help reduce the use of pesticides, put a full bottle of water in your toilet tank to reduce the amount of water used for each flush, don't litter, install solar panels, elect representatives, send letters encouraging global awareness, hang your clothes when they are damp rather than ironing, turn lights off that are not in use, use low voltage bulbs, insulate hot water pipes, plug the tub before turning the water on, install low flow shower heads, turn off the water when your brushing your teeth, volunteer, change a habit, repair instead of replace, plant a tree, encourage car pooling, walk or ride a bike, use rechargeable batteries, buy recycled things, do something nice for the earth, enjoy nature, or make a difference.

For more information on Earth Day and how you can help, go to [www.earthday.net](http://www.earthday.net), and for events in your area go to [www.seirraclub.com](http://www.seirraclub.com).

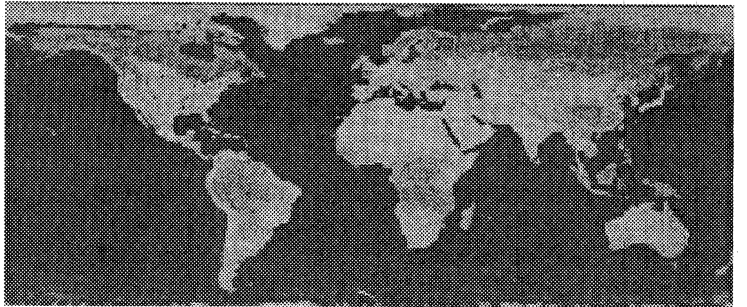

### NASA Continued from Page 2

mance, has been invited to become a permanent member of the team at the NASA Goddard Space Flight Center in Maryland.

Valencia's main interest is environmental sciences and she wants to concentrate her work in the effort to improve the world's environment. The MPLNET's primary function is to determine the vertical profile of aerosol levels and cloud layer heights. Data collected from key sites around the world will help determine aerosol transport and perform ecological and environmental predictions.

In addition to being a student, she is also a physics tutor for ATTIC's tutor lab. For three days a week, she spends several hours

helping students who are struggling with physics. A major influence on

Valencia's decision to pursue a career in science comes from her father, who is a Hydro-Geologist. Eventually, Valencia plans to continue her education in grad school, but for now she is happy and excited about her career opportunity.

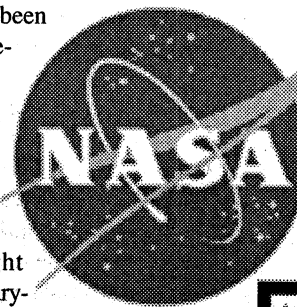

Apply Today!



**STUDENTS  
SUMMER WORK  
\$15.00!**  
base-appl

- Positions available in customer sales and service
- No experience necessary
- Scholarships possible
- Conditions apply, all ages 13+

**770 947 9942**

[worldforstudents.com/cnp](http://worldforstudents.com/cnp)

## Book'it! - "Buy for less, Sell for more"

CHRIS JACKSON

Have you ever purchased a book from a bookstore for a fair amount of money, yet when you wanted to sell the book back at the end of the semester you only got about a third of the price? If this sounds like you, then The Book'it Group has the perfect solution! As part of a senior capstone project in Computer Science, we have built a web-service application called Book'it which allows SPSU students to sell their textbooks to other SPSU students as well as provide an easy and efficient way to search and buy books from other students online. This service is peer-to-peer and is absolutely free! The Book'it Group does not take a "cut" of your profit, and the sell price it completely up to you. Several features Book'it includes are:

- Easy book searching which also displays a required book condition
- Easy viewing of author, title, teacher, and description of the condition
- Uploading of book pictures as well as pictures of the seller
- Registered logins for sellers to allow adding and removing of books
- No login required for buying a book
- Automatic email sent when a buyer has requested your book.
- Accessibility on and off campus

These are just some of the features Book'it has. We ran a beta test earlier this semester and real

SPSU students registered and sold books. Transactions were actually made! And cheap too! The last time I checked there were already 27 sellers using Book'it as well as over 35 books. The best part about Book'it is that we are all SPSU students on a relatively small campus. So once you get an email saying that person X bought your book, you can ar-

about page located at: [http://cscapstone.spsu.edu/~cjackson/about\\_bookit.html](http://cscapstone.spsu.edu/~cjackson/about_bookit.html).

This is a great opportunity long awaited on this campus, so gather those books, put them on Book'it, sit back and relax while students search your books online.

See you soon at: <http://cscapstone.spsu.edu/~cjackson/>

### Terms and Conditions

By using this site, you are agreeing to these terms and conditions which can be changed without advice.

Book'it is not a business or a non-profit organization. We do not sell or buy books nor do we keep an inventory of books to be sold to SPSU students. This is strictly automated, peer-to-peer software which connects to users but does not participate in any part of the transactions made.

Under no circumstances, shall the Book'it system be liable for any damages of any kind (including, but not limited to, invalid sales, lost profits, lost data or any form of special, incidental, indirect damage). By using this site you agree that Book'it system is not liable for any defamatory, offensive or illegal conduct of any user.

range to meet person X at say, the SPSU Globe, in order to complete the transaction.

The system is built using Apache/PHP/PostgreSQL (originally MySQL). More technical design, including database design and features can be found on the Book'it



# ResNet Plans Proposed

DOUG LACHER

With all the construction for the new apartments and renovation for the dormitories, I can't help but wonder what IT has in store for us as well. The new residential network (ResNet for short) will be quite a treat. However, much of ResNet is still in the planning stages, so some of this information could change as work on ResNet progresses.

New hardware has already been purchased to upgrade the dormitories and to install in each of the three buildings that make up the University Courtyard apartments. Currently, money is not yet available for new hardware for the University Commons, but IT is working on that. According to Ron Skopitz, Director of IT, the upgrade of the Commons is a very high priority.

Here's what the proposed ResNet will be made up of and what

its topography will look like. The Commons and Courtyard apartments, the dormitories, the housing administrative office, and the clubhouse will make up ResNet. ResNet will be 10/100 Mbps Ethernet at the wall jack, and there will be a gigabit backbone (1000 Mbps) to carry data from ResNet to the campus network. ResNet will have its own dedicated router to supply its Internet connection. The plan is for ResNet's Internet connection to be completely separate from the campus's Internet connection. The exact speed of the line is still being negotiated. The separate connection for ResNet will allow for better Internet service to the campus residents.

IT also was kind enough to give *The Sting* a copy of the proposed network topography diagram. This may help with visualizing what the new network will "look" like.

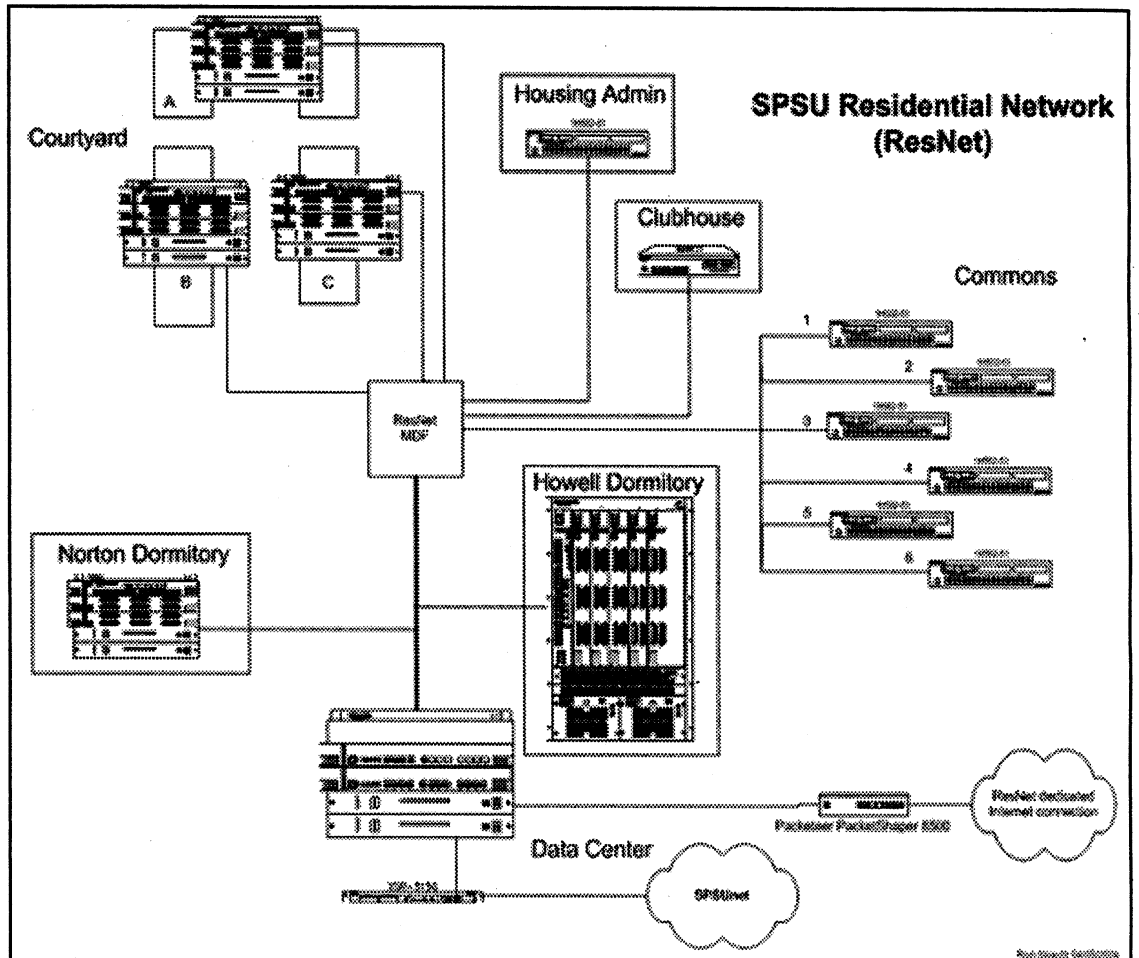

# Pre-Law at SPSU

ERIK HADLEY

The Social and International Studies department has opened up a new degree concentration: Technology and the Law. The idea to offer this new course of study came about as a collective decision from the department faculty, and its curriculum was approved November third of last year. The goal of the new curriculum is to offer students pursuing an international studies degree another option that better prepares them for the L.S.A.T., law school, and a possible career in law. The creation of a pre-law study is a natural move for the department as approximately one quarter of all international studies graduates go on to pursue a legal career.

So will there be a demand for a pre-law degree at SPSU? "Yes," says Dr. Thomas Rotnem, who is coordinating the new degree. There are four very good reasons that the degree will do well at SPSU. First is that there are students already in international studies that want the concentration. Second is interest from undecided students that don't fully have a degree in mind. Third is that many students come to SPSU for one of the technology degrees only to find that it really does not suit them. Many of these students will take a class or two in the international studies to satisfy a core requirement. These students sometimes get their interest peaked by the international studies classes but end up leaving SPSU because they lose interest in their technology degree. Technology and the law may allow these students a way to merge their existing interest in technology with their newly peaked interest in international studies and remain at SPSU. The fourth reason is that a pre-law concentration can be a great tool for recruiting prospective students

# Credit Card Fraud

OFFICER MIKE TARCAN

Who hasn't seen the CitiBank commercials where some beer drinking guy is sitting in his recliner and talking like a valley girl who just bought a leather bustier? Or the woman cleaning out her swimming pool talking like a man about buying a new truck with a V8 engine? It's funny,

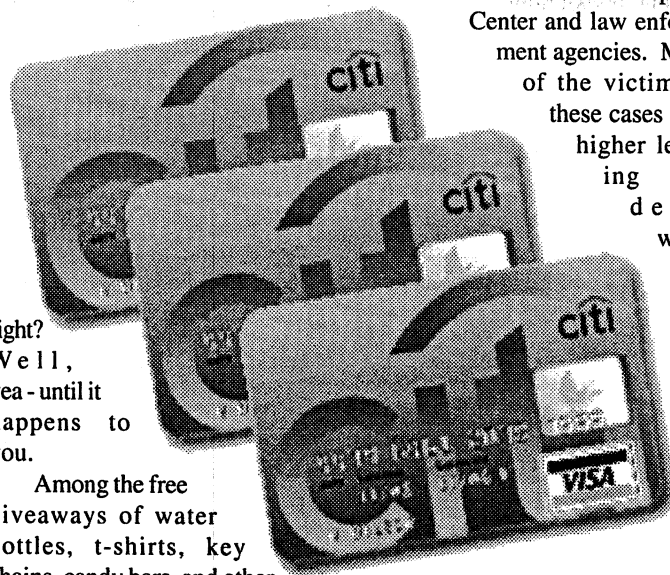

right? Well, yea - until it happens to you.

Among the free giveaways of water bottles, t-shirts, key chains, candy bars, and other

nick-knacks of credit card solicitors on higher learning campuses lies trouble. Incidents of credit card fraud have been increasing since the first Master Card was pressed and mailed in the 1970's. Last year, \$54 million was lost to credit card fraud. These cases were reported to The

Internet Fraud Complaint Center and law enforcement agencies. Many of the victims in

these cases were higher learning students who hap-

hazardly traded their personal information to some guy sitting at a table for a candy bar or t-shirt.

Well, who's really the victim here? The card companies, right? Well, yes, but Bank of America isn't applying for a car loan or putting a wedding ring on layaway. The consumer is the final victim. It can take months to clear a credit history, if you're lucky. There are still costs like higher interest rates.

Currently the two big scams are "Credit Card Fraud" and "Identity Theft". The identity theft is what these crooks are doing as they pass out water bottles and later create accounts with your information. Card fraud describes the taking of a valid card and using it with out the owners consent. The identity theft is more dangerous since the criminal is more difficult to catch, and the crime is not found until you check your credit rating or get turned down for a loan.

The answer is simple. Don't fill out these applications in the stu-

dent center or near the globe. Just keep walking. Not all of these solicitors are crooked, but do you really want to take that chance? Do you really need a free t-shirt anyway? If you want a credit card go to a bank, or go online - where you can be certain your new credit isn't buying some crook's new truck or leather bustier. Any on campus credit card solicitation will be university approved to protect the students, and be highly publicized.

Visit [www.equifax.com](http://www.equifax.com), [www.experian.com](http://www.experian.com), or [www.tuc.com](http://www.tuc.com) to check your credit to be sure no one has made you a victim. Visit the Governor's Office of Consumer Affairs, The US Secret Service, Federal Trade Commission, or FBI's homepages for more information. You can even visit SPSU Police website at [police.spsu.edu](http://police.spsu.edu) for more information.

By the way, if you haven't seen the CitiBank commercials I'm talking about go to: [www.aloraambiance.com/citiwork.htm](http://www.aloraambiance.com/citiwork.htm). They are pretty funny.

who would not normally consider SPSU.

Dr. Rotnem is very excited about the new concentration. "It has the potential to double the number of students in the international studies major," said Dr. Rotnem. What really benefits the school as a whole is that the new major (and the eleven



Dr. Thomas Rotnem is currently coordinating the new pre-law degree.

concentrations) were created with no additional cost or need for faculty enhancement. The necessary courses and faculty already exist; it was just a matter of organizing the curriculum.

This course of study is not just for people with ambitions of going on to law school. The International Studies: Global Technology major is open to anyone that has interest in international studies. The applications range beyond just legal issues. Fully one quarter of the jobs in this country are directly related to exports. This means that one quarter of the jobs in the United States are tied into how companies in the US interact with both the governments and companies of other nations. There is demand for people that understand international relationships and this course of study can better prepare a student to meet that demand.

It is also possible to double major with concentrations in Technology and the Law and many of the other degrees offered at SPSU. "This works very well if you have international intentions for your career, but you have to be highly motivated and focused on your studies from the get go," cautioned Dr. Rotnem. He went on to say that in order to ensure that a double major can be achieved students should check

both with their advisor for their current major and with him for advisement toward the international studies major as coordination between the two will be key.

Any students with interest, questions, concerns, or who would just like to take a look at the new curriculum for Technology and the Law are urged to contact Dr. Thomas Rotnem by phone, email, or stopping by his office in J306.

## Class of 2004

### Congratulations to all graduating students!

*Good Luck getting a job, finding a spouse, having kids, and all that other stuff you are supposed to do in life.*

# Make Earth Day Count Twice Saturday April 24th, by Saving Babies While Saving the Earth!

## March of Dimes Announces New Chair & Teams Up With Captain Planet



**WHAT:** March of Dimes Downtown Atlanta *WalkAmerica* & Captain Planet's Down to Earth Day Kids Fest

**WHERE:** Centennial Olympic Park – Downtown Atlanta

**TIME:** Walk Registration – 7:30am; Walk – 9:00am; Earth Day Activities – 11am-3pm

**COST:** Captain Planet's Down to Earth Day Kids Fest: First 250 *WalkAmerica* participants get in FREE; \$10/person (lunch included)

ATLANTA, GA — Mark your calendars for the most beneficial Earth Day you've ever had on Saturday April 24<sup>th</sup>. This year you could be a superhero by saving babies lives and our planet simultaneously by joining forces with **March of Dimes WalkAmerica presented by Kaiser Permanente and the Captain Planet Foundation!** That's because this year the two organizations have decided to provide Atlantans with two times the opportunities to make a difference in both the local community, as well as on Mother Earth. The March of Dimes is also proud to announce its new Metro *WalkAmerica* Chair, **Mr. Jeffrey T. Fisher**. Plus, special guest & honorary chair **Lois Gibbs**, Executive Director for the Center of Health, Environment and Justice will also be present.

Beginning with registration at 7:30am the March of Dimes 34<sup>th</sup> annual *WalkAmerica* will begin downtown in the historic and popular Centennial Olympic Park. At 9:00am walkers will then embark on a fresh-air, 5.2-mile walk of their own pace throughout the beautiful downtown and midtown areas of Atlanta.

There will even be a *WalkAmerica Fit for Two Fitness Walk* that allows walkers interested in a faster pace to be lead by instructors in different minute-paced groups including a 15, 18, or 22-minute mile.

Adding to these powerful forces will be the March of Dimes Georgia chapter Metro *WalkAmerica* Chair, Mr. Jeffrey T. Fisher. Fisher is currently the vice president and chief financial officer of **Delta Connection, Inc.**, a wholly owned subsidiary of Delta Air Lines, Inc., whose organization is currently ranked number seven in the top ten Georgia corporate supporters. Fisher joined Delta in 1998 and is currently residing with his family in Smyrna, Georgia.

Also at Centennial Olympic Park, the **Captain Planet Foundation** will host its 2<sup>nd</sup> Annual **Down to Earth Day Kids Fest** from 11am-3pm. Here families can spend their day participating in hands-on environmental activities that are led by environmental and conservation professionals from local organizations. Participants can even interact with rescued endangered species from the Ellijay Wildlife Rehab

Center, enjoy amazing live raptor shows presented by the Center for Wildlife Education at Georgia Southern University and much more! Music entertainment will also be provided by Grammy-nominated children's singer/songwriter, **Zak Morgan**. Down to Earth Day Kids Fest tickets are available for \$10.00 each (lunch included). To order your tickets please call 404-878-2929. Contact KP Hendry, Captain Planet Special Events Director for details at 404-522-4212 or 404-522-4260. You may also visit [www.captainplanetfdn.org](http://www.captainplanetfdn.org)

**ABOUT WALKAMERICA**  
The country's oldest walking event, and the March of Dimes' largest fund-raiser, *WalkAmerica* supports lifesaving research and innovative programs that save babies born prematurely or with birth defects. Since its beginning 34 years ago *WalkAmerica* has raised more than \$1 billion to help give babies a fighting chance and takes place on the last weekend in April in nearly 1,500 locations across the nation. For more information about participating in *WalkAmerica* contact Georgia Chapter Associate

*WalkAmerica* Director, Monica Sanghavi at 404-350-9800. Corporate sponsor and walk forms are also available online at [www.walkamerica.org](http://www.walkamerica.org).

### Sponsors

The March of Dimes is proud to announce Kaiser Permanente is returning for a 4<sup>th</sup> year as presenting sponsor of *WalkAmerica*, and Publix Super Markets and Delta Air

Lines are on board as the **state sponsors** for 2004! This year's March of Dimes *WalkAmerica* national sponsors include Kmart, CIGNA, Famous Footwear and Discovery Health Channel.

For More Information (Media Only): Tara Murphy or Jessica Garcia 360 Media, Inc. – 404-577-8686 – [info@360media.net](mailto:info@360media.net)

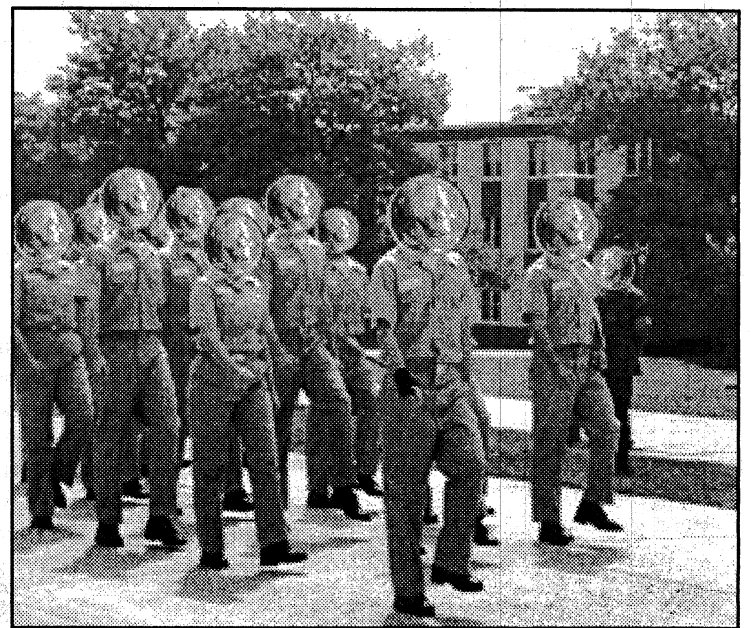

## Farwell to SPSU

MICAH ROWLAND

Here, we are at the end of this road. Saying goodbye to these great halls of knowledge that we once called our home, but this is not the end of our journey. These harsh days and endless nights have prepared us for times ahead that may, in many cases, seem the worst. Never forget these days that are both true and dear, the many wonderful friends, for most their first true love, and a cherished opportunity for the beginning of a new life that once seem so distant. These are the things that an education brings you; it is more than just a simple degree. Many of the special moments here, at Southern Polytechnic State University, will last with us for the remainder of, what we will call, a lifetime. But, the things we gave to the campus by helping each other and being true friends will embed themselves in the culture of SPSU and last for many lifetimes. At times, it is hard to see but, by dedicating yourself to the many educational growing opportunities and many various social events, you can see how an educational community can come together and lend a hand in teaching the future leaders, technological

professionals, and construction developers of the Southeast and the entire nation.

SPSU have collected some of America's most experience and

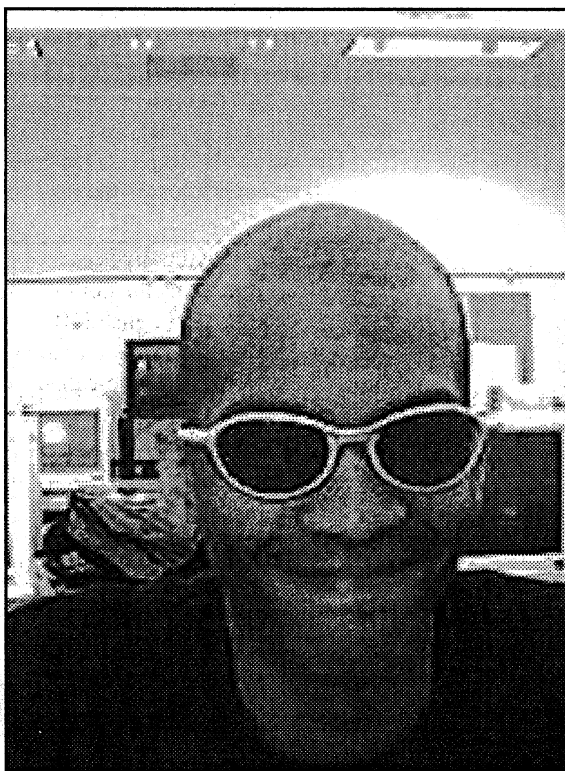

Congratulations! From The Sting Staff

credible faculty and professionals to provide a very powerful technological degree in many of today's most demanding careers and professions. I can very much tell you

that I feel very confident about the education that I have acquired at SPSU, and the opportunities that I have gain working here in the Computer Science Lab at J-263 was a very good life learning experience. One experience, I remember that I would like to mention is my encounter with Computer Science faculty, Dr. Robert Harbort. I spent a majority of my time in the CSLab, so I can guarantee that you can see Professor Harbort in the computer science lab dragging some students to his classroom, trying to ensure that they do not miss out of any critical knowledge he is preparing for that day. I was one of those students a few times. I also would like to mention the great emphasis he and Professor Robert Brown places on academic honesty and their ideas on requiring students to just make a

reasonable effort in completing class assignments. Another experience I would like to mention is the great dedication of professors like Dr. Frank Tsui. Professor Tsui creates a Software Project Management environment that keeps us on our toes and explains the rationale behind real world software project management techniques and skills that are supported by real world examples. He ensures that you have obtained the necessary skills to become successful in Software Development by monitoring your work and responding with valuable feedback and consultation on how one may improve their work. Dr. Ju Andy Wang's class has been a wonderful experience and sparked a continuously growing desire in learning various skills and techniques in developing secure information technology infrastructures. In the management department, you have professors and instructors, like Professor Russell Jones and Alas Muhktar, who communicate and help, inspire the spsu students and help give advice and encouragement for the personal growth of various students. There are also terrific faculty leaders, like

Dr. Becky Rutherford, who has helped me with the proper guidance and assistance in scheduling the proper courses in acquiring the specific needs to become an exceptional Information Technology Professional and Information Technology Management Student here at Southern Polytechnic State University. I could go on and on but each of us has shared some unforgettable moment here at SPSU that will be engraved in our hearts and minds for the rest of our years.

So it is with that that I say, "Farewell," to SPSU and "Thanks for so many wonderful years." I saying, "Farewell" to SPSU is like a departure from so many wonderful friends.

Are You Looking for a Place to Live?  
Are You a Homeowner  
Looking for a Tenant to Live in Your Home?

HOUSEMATE MATCH has Helped  
the Community with Housing for 30 Years.  
Confidential Interviews.

For More Information Please Call:  
Lynne Dyckman  
770-578-7526  
[lynne.dyckman@alliantajpc.org](mailto:lynne.dyckman@alliantajpc.org)

# SPSU: All About the Bottom Line

## CONTRIBUTED

It has become increasingly apparent in the years since I have attended Southern Tech that administrators are not concerned with quality of service at all. They are concerned with the bottom line—a figure of speech referring to the main or final result. In this editorial piece, I am going to discuss why I think this by providing a broad base of supporting evidence, and then conclude with my thoughts and interpretation of the situation.

The SPSU Administration and those under them—and by that I mean all staff members not directly involved in instruction—have elected repeatedly to disregard the wishes, concerns and at times, the legal rights of the students they serve. Notice I use the word “serve,” because I believe that as students who pay tuition and other fees in exchange for an education, we are customers. Do not buy into Dr. Rossbacher’s well-woven spin about industry being the customer. One of her goals in creating that ridiculous analogy is to excuse her lack of service to you, the student.

Fact: the administration will also claim fame in working to provide services and improve campus in general. What they do not tell

fourth of the campus is torn apart as an “Ed Klein-sponsored construction catastrophe” is in progress. The school is increasing its residence capacity so that they can change how the State defines and categorizes the institution. This means more money from the government and most likely, a second or many tuition hikes to come. Besides all that, ResLife did not warn residence students to the extent of loud, dirty work to take place right outside their rooms. Some of them might have chosen other places to live. I know you cannot sleep, study or think straight. Rest assured that someone cares: your fellow students. It is not an innovative initiative; it is a drive to increase the taxable populace.

The Career and Counseling Center is an absolute joke. There are a small handful of actually useful services provided by the Career and Counseling Center; everything else serves as self-justification. I can personally recall one well-qualified and kind worker in the Career and Counseling Center, but because I do not want him or her singled out or attacked, I will not mention a name. Nevertheless, you do not have to remain in suspense, visit the Center and partake in the various services

ceives money for each meal plan to purchased, and possibly, additionally each meal purchased. The dirty, down-to-earth term for this is a “kick-back.” The university has also arranged to receive several thousands of dollars worth of free catering. This “free catering” is not free, just free to them; YOU are paying for it. All of this was discussed and agreed upon by both SPSU and ABL. The school is also under obligation to perform upgrades to the dining area as part of the deal. They have been extremely slow and non-responsive with ABL getting that work done. Think about how much better the food could be if all of the money went to the actual cost of maintaining the service. That may be to novel an idea, and so I will move on.

The Bookstore is outright, outrageous and outlandish. You cannot get their prices from them on the phone, they are overpriced and they will give you a dandy nickel for all the books you have now. The Bookstore is only present with the permission of the school, and yes, the school gets another dandy handout to let them stay. To begin with, you should know that the Bookstore is a part of Barnes & Noble and that 99.9% of their prices are based on Barnes & Noble’s prices. If you need to know what the price of a book at the Bookstore is, look it up on Barnes & Noble’s web site and then do what everyone else does: walk across the street to Southern Engineer’s Bookstore. Seriously, if you do not know where this is, ask your friends until you find it. Sell your books there too, they sell for less AND pay more.

On the other hand, keep in mind that academia is a unique industry in western culture: it is the only business that has the built-in social expectation that the customers (students) are not to be treated as such. Case in point: you pay to attend school here and yet you have the most underprivileged parking available—assuming parking is available after the administration, faculty, staff and plunger-wielding janitors—all of whom are paid to grace us with their presence on at least a semi-daily basis—have parked. Their apathy and lack of concern for you are by no means original nor out of the ordinary.

If you care to do so, you can cut them a little slack and understand the human beings behind the titles. These people have had successful careers, hold doctorates and are generally responsible for their personal lives (at least to the extent of which I am aware). It is not that they are lazy; they just do not care. If they work a little harder and make the students happy by treating them fairly, they do not see another dime. Their only real motivation is the fear of losing their jobs, but that will only make someone work hard enough not to be fired.

offered. It is too damned obvious who is doing his or her job. The Career and Counseling Center is not a service extended for your benefit, it helps to validate the school.

Another hot topic that begs to be discussed is ABL, a food service company primarily associated with correctional facilities in Louisiana. Clarification: you are eating prison food. Nevertheless, taking a step back from the entire situation reveals the true culprit of this whole situation. The SPSU Administration re-



What a nice picture for such a condescending article.

you is that often these changes are being mandated by the State, or they have found a new way to suck money out of you.

Would you like a demonstrated example? I have several of them.

The Residence Life Department is responsible for what I would consider to be amongst the most horrible student disservices in quite a while. If you live in Howell or Norton, I am so sorry. For those of you that have not seen or heard, a

## Sting Staff

Miranda Bennett, Editor-in-Chief

Christopher Aiken	Douglas Lacher	Todd Pish
Karen Asay	Benjamin Lee	Micah Rowland
Chris Bennett	Vincent Migliore	CJ Shrader
Mark Campbell	Tom Mitchell	CJ Shiflett
Deven Gallo	Krystalyn Norton	Kenny White
Jim Hill	Tony Perez	Benjamin Yampolsky
Bailey Humphries	Daniel Perry	

*The Sting* is published biweekly for the students, faculty and staff of Southern Polytechnic State University. *The Sting* is an official publication of the students of Southern Polytechnic State University. The ideas expressed herein are those of the Editor or of the individual authors, and do not necessarily reflect the views of students, faculty or staff at Southern Polytechnic State University or the University System of Georgia. All material in *The Sting* is property of Southern Polytechnic State University and cannot be reproduced in any manner without the express written consent of *The Sting*. No advertisement in *The Sting* represents an endorsement of Southern Polytechnic State University or *The Sting*, and neither *The Sting* nor Southern Polytechnic State University is liable for any claims for products or services made in advertisements herein.

## ADVERTISING INFORMATION

The local advertising rate of *The Sting* is \$3 per column inch on paper; advertisements online are determined by frequency. Advertisements for service and professional organizations on campus are free, but a run-date is not guaranteed on paper. To guarantee one, ad rates are one half the local advertisement rate. Classified advertisements are \$25.00 for the first 25 words on paper; online classifieds are \$12.00 for the first 25 words. Advertisements must be submitted by the deadline printed below. To reserve space or for more information, contact *The Sting* at 770.528.7310 or sting@spsu.edu.

## LETTERS TO THE EDITOR

*The Sting* welcomes letters praising or criticizing editorial policies or opinions. Letters should be typed or neatly printed, double spaced and should not exceed three hundred words. Letters must include a name, address, and phone number for verification purposes, but names can be withheld upon request. Unsigned or unverified letters will not be printed. *The Sting* reserves the right to edit letters for style, content or size. All letters are run on a space-available basis. Please send all letters to *The Sting*, Southern Polytechnic State University, 1100 South Marietta Pkwy, Marietta, GA 30060, or drop them in the box outside of our office in A252, or email sting@spsu.edu.

## ORGANIZATIONS

Articles written by organizations to inform the campus of activities and events are welcome. Articles must be submitted in electronic format (email, disk) by the deadline printed below. Please limit articles to two hundred words. All such articles are subject to editing for style, content and size, and are run on a space-available basis.

## JOINING *The Sting*

Any student paying Activity Fees is eligible to join *The Sting*, though final decision is made by the Editor-in-Chief. We prefer creative students who have passed English 1101. Come to our meetings Friday at 12:00 p.m. in A252, upstairs in the student center, or call 770.528.7310. This includes YOU, all you so-called members that never attend. *The Sting*: It's not a job, 'cause a real job pays more.

## DEADLINE

Deadline for the next issue and its release date will be determined by and announced by the incoming Editor-in-Chief. Please contact the incoming Editor-in-Chief at sting@spsu.edu for further details.

## SUBSCRIPTIONS

Subscriptions to *The Sting* are \$1,000,000 per semester or \$5,000,000 an academic year. All subscriptions start with the first issue of the succeeding semester. Checks for subscriptions should be made payable to *The Sting*.

## PRICE

*The Sting* offers to every student, faculty, staff member, alumni, and official visitor of Southern Polytechnic State University copies of each issue numbering up to 0.25% of the print run for the respective issue. Every copy above 0.25% is to be purchased according to a price set by *The Sting*. Taking more copies of an issue than constitutes 0.25% of the print run of a particular issue is THEFT and a criminal offense.

Join *The Sting*  
That's it. Just join.



# Time to Call a Spade a Spade

BY: ERIK HADLEY

I feel the need to vent some views and observations. To start lets begin with Israel. If you spend anytime listening to international news you hear about the fighting going on between Palestinian "militants" and Israeli soldiers. You hear about Israeli soldiers raiding Palestinian settlements and capturing or killing these same militants. You hear about Palestinian suicide bombers blowing themselves up on a crowded bus or in a crowded market place. Then you hear about how the Israelis retaliate by killing the leaders of the organizations responsible for the bombings.

So what's wrong with all this? Well for starters let's begin with the word militant. These Palestinians are not militants, they are terrorists. They are not fighting for freedom, they are blowing up civilians. They are not suicide bombers, they are homicide bombers. They are committing acts of murder every time they blow themselves up. Take a look at the footage of the aftermath of an attack by these bombers. Take a look at the bodies of the dead or dying women and children. Murder, that's all it is. But then what happens the Israelis try to eliminate more of the terrorist organizations that are attacking

them? The Israelis get blamed for defending themselves!

Israel has tried to build a wall to cordon off some of the areas where the Palestinian terrorists live. The idea being that the wall will keep the terrorists out. So what happens when Israel tries to build the wall? You have the United Nations condemning Israel for building a wall because it is divisive. Yeah that's right, it keeps people out so it's a bad thing. Israel taking measures to protect its own people is a bad thing according to the U.N.

But the U.N. knows best doesn't it? After all, the U.N. has such a great track record when it comes to dealing with conflict between peoples. The U.N.'s most shining example probably comes to us about ten years ago in Rwanda. What happened in Rwanda you ask? Simple, genocide happened. No wait, it wasn't genocide, it was only acts of genocide. You see ever since the holocaust during World War Two many countries signed treaties stating that they would be obligated to intervene should a case of genocide ever occur again. Well in Rwanda we had two different groups of people, the Hutu, and the Tutsis who began to murder each other. I will not go into all the details in this editorial but

the end result was that both groups were attempting to eradicate each other. Millions of people were slaughtered. What did the U.N., that wonderful organization dedicated to peace, do? Nothing. That's right, the U.N. did nothing. They sat back and let the killing happen.

But the United States gets a clean pass in this, right? We did something, right? Nope, sorry we didn't. Like I said earlier it was acts of genocide, not genocide. You see the Clinton administration along with the rest of the treaty-bound nations realized that if they didn't call it genocide then it wasn't genocide and they didn't have to get involved. So what is the difference between acts of genocide and genocide? Beats me, but Bill Clinton understood the difference. So the world (with the United States included) sat back and did nothing.

Did all this really happen you ask? The answer is yes. But don't just take my word for it, look it up. Look into what's happened in the world. Don't just live by the thirty second sound bites on the TV. Read articles, check multiple sources, form your own opinion. If you don't know where to start looking for information why don't you try talking with one of the professors in the Social and International Studies department? They should be able to point you in the right direction.

# Letter to the Editor,

[The article referred to was printed in the March 3, 2004 issue of The Sting. This letter wasn't included in the April Fool's edition, due to its serious nature. - Sting Editor-in-Chief]

The Career and Counseling staff feels it is important to respond to the letter about career services in your last issue.

No students are ever guaranteed employment; in fact, we continually stress the fact that all employment is cyclical and that the fact that a major is in great demand today does not mean that will be the case in the future. We maintain contact with thousands of current and potential employers, but have no way of forcing them to have openings for any major. The job market for any computer related area 3 or 4 years ago was phenomenal and most graduates were receiving multiple offers. Most people who read the papers or watch the news know that market virtually died about 2 years ago. Not only did employers stop hiring new staff, they were forced to terminate many, and in some cases, all of their existing employees. Over the past few months we have begun to see some growth in computer related jobs, but it continues to be a very tight market. In any tight market, those students with the best skills, related experience, the ability to be flexible, and the willingness to put forth their own efforts in their job search will have the greatest opportunities.

For the student who wrote the letter in the last issue, it is hard for

a point of reference, Georgia Tech, which offers similar types of programs, has more than 6 times the staff we have to provide the same services to approximately 4 times the number of students - and they never promise anyone a job either.

The functions of the Career and Counseling Center include providing workshops and class presentations on a wide variety of counseling and career topics, working with individual students, assisting employers in meeting their job needs, and assisting students and alumni in their job search. In that effort, the career staff in our office provides workshops and class presentations on a variety of topics including resume preparation, interviewing skills, and networking; provides career and interest testing; works with individual students in resume development and interview preparation; provides programs such as the career fair; offers Co-op and Internship programs to assist students in gaining related experience; and provides access through resume referral and/or campus interviewing for employment opportunities. This is, of course, in addition to a wide variety of other duties and activities performed by our staff.

This is not an easy job. It is only due to the amazing level of hard work and dedication on the part of the Career and Counseling staff that all of these services are provided for the benefit of the students and alumni of Southern Polytechnic.

Regenia Doyle, Director

# How to Get Out of Class

Editor,

I was recently disgusted by Anonymous\*Mew,\* "How to Get Out of Class for a Day." (Vol LVIII, Issue 9 - Thursday, April 01, 2004) The article was such rubbish that I didn't read past the third paragraph. A word of advice to your readers, these tactics don't work. I will give you three that have been tried and tested:

## Sick: Get a Note

I created my own letters by duplicating my current doctors "sick notes." He used a pad (4x6) that stated the clinics name, the address and the phone number. It also had room for memo and a little area where he was to sign or write a prescription. My entire college career, I used a sick note printed off my laser printer, then printed off of a high quality copier. I then scribbled in doctor's writing my illness (taken from a doctor's book- so it was in doctor's terms) and how long it was recommended for me to miss class. Not one teacher batted an eye - not even Pam Fritzi.

## Tell a story about a true accident that you witnessed, or you didn't.

My second tactic was to call my professor, sometime the middle of my class, and leave a message. The message generally was a story about how I was at Starbucks that morning when I witnessed a 4-Runner tip over while turning into the

parking lot (it was hit by another car). You then tell the professor that you ran into Starbucks, grabbed the fire extinguisher and ran back out. When you got to the car you realized that there were two kids, small in age, in the car who were terribly frightened because their father had blood all over his face from where the drivers window smashed. You can say you comforted the kids or helped the father or just say you climbed into the vehicle because the fumes were getting so strong that the engine had to be turned off. I have used this countless times. I even used it when I was late to a job interview because I slept in (and I got the job!). The fact is, I did witness and take part in this exact scenario - it just happened 5 years ago.

## Miss an exam with this one - car trouble

Again, call in the middle of your exam from your cell phone on the highway. I would call my professors and tell them that I ran over a

strange looking pronged tool that flattened my tire. I would then tell them that I couldn't change my tire because I didn't have a jack or the tire was too heavy to lift out of my trunk. I would then tell them I was waiting for AAA, and they did not know how long help would take. I always offered for them to call me back on my cell phone. In which they always would and this time you are either sitting in your car waiting for help or let it roll to voicemail. In the event of voice mail, call them back when you get home or get to campus telling them your battery went dead.

As I said, these have all been tried and tested. You must be a good actor and not too lazy to pull these off. It's about putting yourself forward and explaining a situation and then offering to make it up that day! I've never been busted and I've used them since high school and through college. Take it from a pro, don't act sick!

Your former editor,  
Mercedes Bankston



you to believe you have spent much time working with our office since you don't appear to know anything about our staff. Our office, which is the Career and Counseling Center, not the Career Placement Office, is staffed with a Director, 2 Counselors - one specializing in personal counseling and the other primarily providing career counseling, 1 Co-op and Internship Coordinator, 1 Career/Placement Specialist, and 2 secretarial/support staff members. If you can let us know who those two Ph.D's are, we would certainly like to meet them. For those of you who are unaware of the facts, that is a very small staff to provide the large number of services offered through our Center. As

# Maple Garden

Thai • Chinese • Sushi Bar

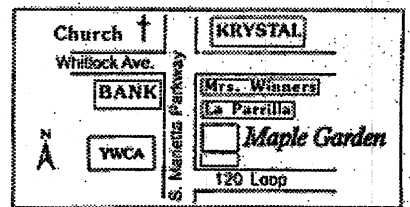

**10% off with Student ID**

**Dine-In • Carry Out Delivery**

Minimum Lunch Delivery \$10.00 (Limited Area)  
Minimum Dinner Delivery \$15.00 (Limited Area)

## Business Hours

**LUNCH**  
Sunday - Friday 11:00 a.m. - 3:30 p.m.  
**Dinner**  
Sunday - Saturday 3:30 p.m. - 10:00 p.m.

**770-218-8755**  
**770-218-2836**  
Fax: 770-218-8819

**35 S. Marietta Pkwy. S.W.**  
**Marietta, GA 30064**

# Mom and Pop's Student Housing -

## It is time for a Change in Student Housing at SPSU

Letter to the Editor,

I would like to take this opportunity to point out a situation that has been on the minds of many Housing residents this semester. As apparent there has been a lot of construction taking place on campus related to the new University Courtyard apartments. However, what is not so obvious is the construction taking place in Norton Hall. Among the renovations taking place while students are living in the building is the installation of an elevator in the center of the building. For the first month of the semester the residents of Norton Hall were awoken every morning at 7am to the sound of jack hammers chiseling out the concrete staircase agonizingly slow. Every day this con-

lished several years back there was an outcry from the residents. The concerns were lack of options, quality of food, and the price. Currently the least meals we can buy are 14 per week even though I only eat at most 9 each week. There are no credits or refunds and \$950 is just too expensive. If we have to overcharge students to make sure something is profitable then maybe the meal plans aren't such a good idea or at least more flexible plans would be appropriate. On many instances students must sift thru the silverware, plates, and glasses looking for ones that have been cleaned properly. There is just something about seeing a greasy film on your drink glass or hardened food on your fork that just really makes one lose their appetite.

tracts for next year. As you can probably imagine by now, we were hit with another surprise. When we originally applied with the housing office we sent with our application a refundable \$75 application fee. That fee has been increased to **\$150** and is now **non-refundable**. That's freaking expensive to process a piece of paper and assign someone a room. Student housing is supposed to be a service to the students, not a financial rip-off and harassment session. There should be a full disclosure as to where this money is going and the reasons behind this.

I would hope that the housing office is telling incoming freshmen, and their parents, about how Housing really works on this campus.

Prices and conditions are going to change without prior notification. Most importantly, changes will be made by the housing office that will greatly affect student's lives and the housing office is going to make no effort what so ever to acquire student opinions or suggestions prior to decision being made.

The big question here is... **who is making these sorts of decisions?** It should be clear by now that the students are not the #1 priority. What is the underlying goal behind all this? Supposedly, it is to create a more sociable environment for students—or whatever. Making decisions that residents do not support, or have no input in is not a good way to start. In light of the budget crisis, this university must look at the contribution these people make to SPSU and debate whether or not they should be on the payroll. Fire all of these people, fire the whole housing staff, give us our \$150 back, charge a reasonable application-processing fee of \$10, and find someone competent to head the housing office. Hire a whole new Housing Office staff that can be trusted and liked by the residents.

Surely someone from Housing or Administration is going to fire back with excuses but those who are really concerned with this matter should not only read this letter but do a little investigation for yourself. Go to the Housing office ask to see a housing contract and see if you can find prices and then look at the terms and conditions for breaking the contract. Look behind Norton dorm at all the material that has been removed from the building and think about all the noise that was made over the last 3+ months in removing this material. Go eat lunch in the cafeteria, judge the quality and price of the food, and ask some of the students their opinions. See if you think another price hike of 10%+ is warranted again this summer.

Of course, I'm not going to level all of these charges without offer-

ing suggestions. First, the top priority of the Housing office should be to stand up for what is in the residents' best interest. Listen to the residents and ask for suggestions. Instead of having useless hall meetings discussing rules that the Housing Office does not enforce anyway, use these meetings to discuss possible changes and ask for suggestions. Many people on this campus are smarter than the ones making the decisions in the Housing Office. Create more options for residents concerning room assignments, meal plans, and contracts. For example, offer 7 meal/week plans or refund portions of unused meals. From what I hear, there was once a declining balance plan that was popular. Offer contracts per semester and give us ample time to explore other housing options. Enforce rules and stay with original agreements unless it is absolutely necessary to break them and even then give students options. By phasing in many of these plans upperclassmen that are not happy with the changes will have time to complete their studies before changes go into effect. Freshmen residents have not spent as much time here; therefore, it is much easier for them to transfer to another university. Finally, no construction should take place on the dorms while students are living there. One dorm is closed each summer and this is rotated. Schedule construction for the summer in which that particular dorm is closed.

Since the student residents have not been able to voice their concerns, I would like to ask the faculty for help. In meetings, or casual conversations with the decision makers please inquire about these issues and ask what the feedback from the residents has been. By bringing attention to this, then someone will have to address these issues.

Signed,  
Concerned Student Housing Residents

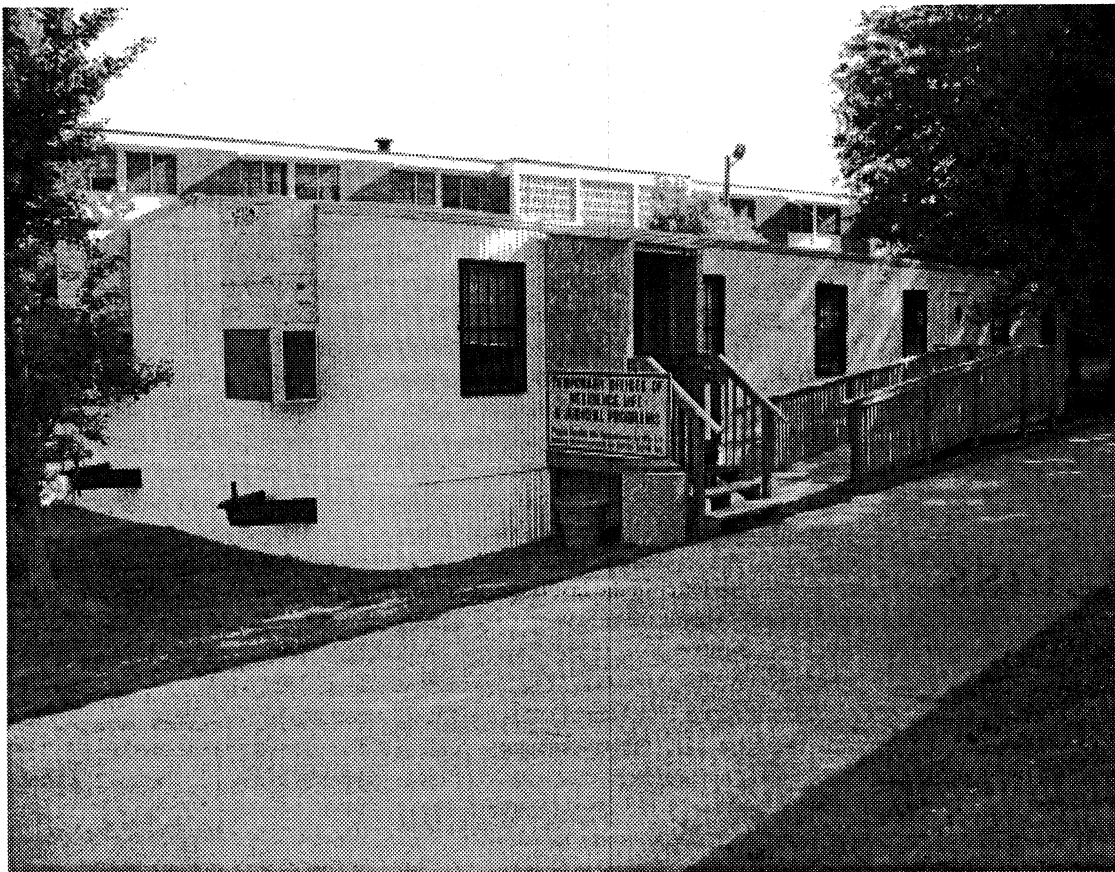

You too can be on the Jerry Springer Show!

tinued until 4 pm. We couldn't study, hear the stereo or TV, or even talk on the phone because the noise was so loud. Every day we returned from class to clouds of cement dust in the hallways and rooms. Did anyone from housing ask if there was anyone with respiratory conditions in the dorm? No! I can understand that many departments or entities of SPSU took part in this decision; however, the responsibility of the housing office should be stand up for the residents and ensure there is an environment for learning. The most absurd part of this is that Norton Dorm will be closed this summer. Why couldn't these renovations wait a few months and the construction crews could have full access to the building. Or, why can't an external elevator be built like the ones on the Math and the Electrical Engineering buildings that would be less invasive?

It's sad to say to that this is just another example of many instances where the Housing Office has shown little respect for the resident's living conditions and have not accepted input on matters that greatly effect students' lives and studies. The meal plan is another good example of this. When the mandatory meal plan was estab-

So much for quality! Thanks SPSU

In addition, if we want to be guaranteed a spot in on campus housing in August we have to sign contracts in March. During a semester and a half, a lot can change and maybe an alternative housing arrangement may be better, but we are stuck in a contract. Any contract for students should be per semester. When we do arrive back in August we are usually hit with the surprise that the price for a dorm room has been raised and also the meal plan has increased. Just last summer the price for the 14 meal/week plan was increased by \$150. I went back and looked at the contract from the previous spring and there are no prices listed. So, if a student wants to live on campus they must sign a binding contract with no assurance in return of what the price will be and that an environment conducive to **learning** will be guaranteed. Students who do live on campus often do so for financial or transportation reasons and their options are limited. They shouldn't be continuously sucked into fee hikes and contracts. That is nothing more than mere harassment.

All campus residents including apartments are now signing con-

Basically things are going to be made up as we go along and the students are required to hold up to agreements while housing will certainly do whatever they want.

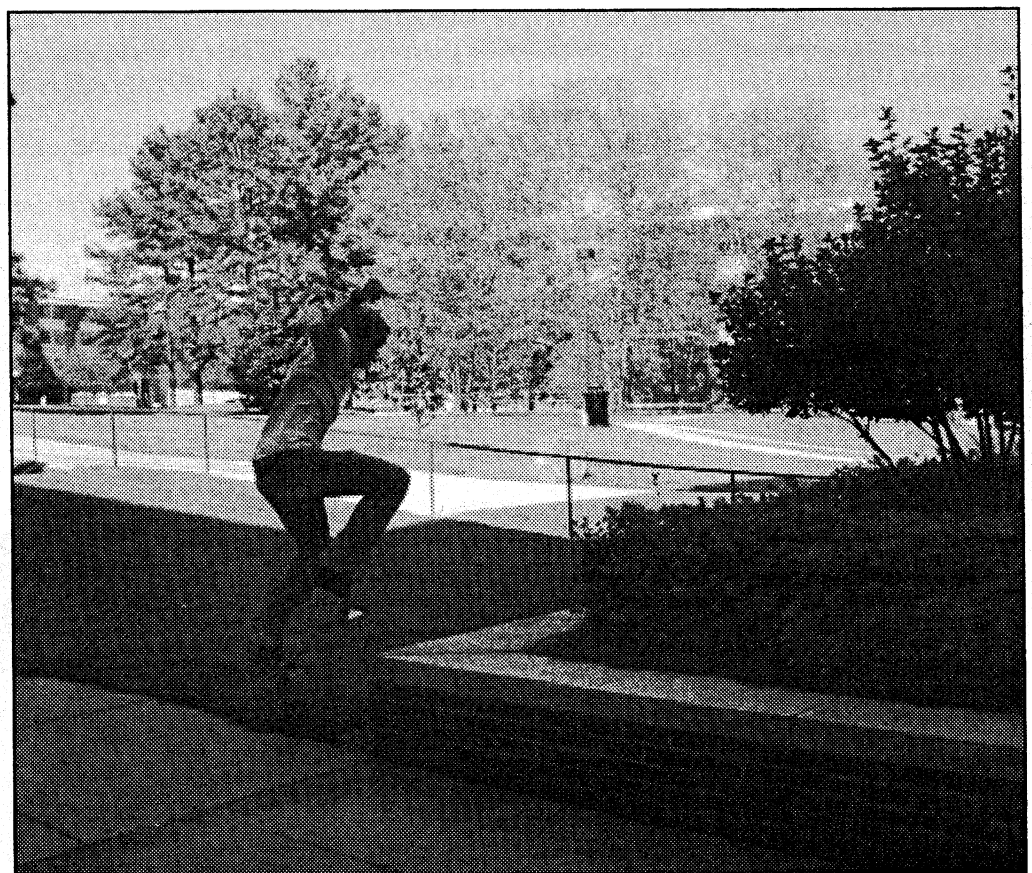

SPSU Skate Park Admission: \$1,377.00

# The Soap Box Farewell

MIRANDA BENNETT

At the onset of my "reign" as Editor-in-Chief, I was gently reminded of the balance between freedom of speech and responsible editorial review. I was also gently encouraged not to stand on a soapbox preaching about it all the time. For the most part, I think I've made reasonable editorial choices and I've kept my soapbox safely tucked away. However, now that I'm on my way out, I think I'll step up.

I was inspired to write this article after learning about worries over the perceived sexual and racial tones in The Sting. I was more inspired when I was recently told that one student was going to the



This is Miranda's soap box

president of the university with similar concerns and that another may go to the Student Life Committee. Additionally, I was reminded that The Sting has a reputation for being "cliquish," and vindictive.

I've heard these sentiments often and on all year, but generally in the context of someone who wanted to affect The Sting without actually contributing. However, I have also considered that many students may just be ill-informed and, as a result, have poorly formed conceptions about The Sting. So, I'll try to better inform and thereby, hopefully defeat some misconceptions.

First, I'll address what The Sting can and cannot print. As you may know, The Sting is protected by the first amendment. (I know, you're thinking "well, duh"...I'm on my soapbox, remember?) That doesn't mean protected until someone is offended. The Sting is absolutely entitled to print anything that is not legally defined as obscene and not considered libelous – no matter how offensive that content may be.

What The Sting may not print is libelous or obscene content. Libel is the printing of something untrue, knowing it is untrue, purposefully and with malicious intent. Libel can be presented as news, opinion, entertainment – it doesn't matter as long as it fulfills those three requirements. For example, articles in the April Fools edition were known to be untrue and were purposefully printed with that knowledge but, they were not malicious. Legally obscene essentially means no "penetration," however The Sting can legally print full frontal nudity.

You may have been offended or turned off by an issue or several issues of The Sting or maybe just one article. What can you do? I'll tell you, but first - I should explain what will least effectively change The Sting. Neither going above The Sting nor bullying The Sting will effectively bring change. Storming into the office or filling The Sting's inbox with a tidy list of insults and demands won't do the trick. Honey attracts more flies than vinegar. You don't have to kiss up, but it does go better when you don't bite. Further, although anyone (readers, fac-

ulty, staff, parents, etc.) may speak to The Sting's advisor, the president of the university, or the Student Life Committee, there is absolutely no chance that any of these will force The Sting to "tone it down" or force it to print anything. They may only intercede by giving counsel or encouraging moderation.

If you're a student, be grateful. It's your newspaper and you shouldn't want the university or any of its minions controlling what

you can read or write. If The Sting is to be effective and truly serve the student body, it cannot be in a position to be neutered or bullied all the time. It

must be autonomous.

Now, I should get to the part that explains why SPSU won't put The Sting in its place. There is a trade off for The Sting's autonomy. What's that? Well, guess who's legally responsible for The Sting – me, or rather the Editor-in-Chief (who will thankfully not be me very shortly). The university can't interfere with the student newspaper because they're not liable for it. And, because I, as the Editor-in-Chief, am personally responsible, I get to boss the staff around...but, not too much, unless they leave and I have to do all the investigating, writing, editing, laying out, dealing with the printer, distributing.....(inhale) and so on. Let me revise. I get to edit the staff's stuff while they're not looking and beg Barry to pay for pizza for the meeting. I also get to strut around and talk about how cool The Sting is and how cool I am. Moving on.

By now you're thinking, "Oh great...we're doomed. They're going to print that squirrel and battered women article until dooms day." Well...maybe. I don't know. Like I said, I won't be here much longer. The next Editor-in-Chief will make that determination. However, I can tell you how to effectively change the tone and content of The Sting – participate.

I predict that the next Editor-in-Chief will carry on the practice of accepting and printing almost all submissions. The Sting accepts almost everything turned in. I consider myself terribly strict compared to the whimsical Mr. Jones, and I've only turned away two submissions all year, though I have shot down a fair number of off-the-wall ideas by sleep-deprived staff members during layout.

If you want to make a difference, if you want to truly have a voice, then get involved. Write an article. Come to a meeting. Compile a calendar of local events that speaks to the issue that concerns you. Take photographs. For goodness sake....sell advertisements!!! There is so much you can do that can shape The Sting.

The Sting staff put themselves out there every issue to be criticized. They take the risk, which, I suppose,

explains why they're generally more comfortable with edgy material. If you truly want to influence The Sting, then take a risk too. Make a contribution. At the minimum, initiate a dialogue with the Editor-in-Chief. Don't just try to take the safe route by going over heads in hopes of finding someone willing to force The Sting to change. Change it yourself!

To illustrate what happens when people change The Sting by participating, I offer as an example the experience of alum and former Sting staff member Marlana Compton who once had a problem with The Sting. To address her issue, she wrote. She wrote a lot and she wrote well. You can look her up on the staff page on The Sting Online at [www.thesting.org](http://www.thesting.org). She influenced the student paper and made it more like the newspaper she wanted for her university by writing and coming to meetings.

If you're going to change The Sting, you probably want to know who you're dealing with and I'm sure you've heard plenty about The Sting staff already. But, forget that because here's my version of the truth and I'm right. The Sting is a bunch of volunteers, generally from degree programs so removed from journalism that you have to wonder what they're even doing on a student newspaper. The staff has always been, in my experience, and continues to be incredibly tolerant of other ideas, cultures, and life styles. It has, in most cases, been more diverse than many other student organizations on campus.

Don't let others discourage you from checking out The Sting based on their experience with the staff. Try it for yourself. The Sting is not exclusive or a "clique" – it is a close-knit group of volunteers with a common interest and purpose. Yes, the paper has some inside jokes, though I contend that many are just the silly ones that seem cool at 3:00 a.m. (Kiss my Glass?). If you don't like inside jokes then, as one staff member put it, get on the inside! Join the Sting or just ask a staff member what the joke is about. I don't think anyone on staff would mind retelling our lame jokes. After all, we think they're funny.

You should wonder why I'm so

dead set on defending the newspaper. Why is The Sting so important? Why do I strut around and talk about how cool it is?

This paper has on occasion been called a two-bit rag, fish wrapper, and "nothing merely as a tabloid." And maybe, on occasion it has been all of those. But, it has also done great things. It has a history of incredible accomplishments by dedicated staff members who were never willing to publicly brag. That's okay. I don't mind bragging on their behalf.

During Anne Bartone's editorship (before my time), The Sting uncovered a "glitch" in one of the state's servers. The server was allowing Google to scan and cache student social security numbers. The discovery was so significant that it resulted in financial aid being shut down throughout the state for several months, it was picked up on the newswire seven times, the GBI and several major news sources in the local area actually visited The Sting office, and the two reporters that carried it off, Mark Campbell and Kamie Harkins, won first place at the Georgia College Press Association conference for Best Investigative Reporting – beating big name universities with sizeable journalism degrees.

The Sting runs its online edition on a proprietary content management system developed by the former Web Manager Daniel Henry. As I write, the current GrandHigh Server Guy (yep, it is his official title – that's what you get for giving yourself a title longer than mine)....anyway, the GrandHigh Server Guy Doug Lacher is working on a second proprietary content management system for The Sting. What's the significance? Many other university newspapers purchase their websites or content management systems. Even SPSU outsourced its website, but not The Sting!

And, I must mention the modern day father of The Sting – Zachary Jones, who resurrected the neglected publication from nothing. He is The Sting's very own hero, even if he is just a short Dominican with an unaccredited degree. Just keeping The Sting going is hard work, I can't imagine the dedication

it took to get it off the ground. Without Zachary Jones, there would be no paper and you, the reader, would only know what you hear through the grapevine.

The Sting is awesome! It's serious business, even if it does breed lame jokes and a never-ending parade of squirrels. Sting tradition demonstrates that The Sting not only prints squirrels and battered women articles, but also prints articles on current events, opinion pieces about racial issues, sports, and articles on a myriad of other topics. The Sting has a purpose that is much more important than its constantly changing tone and much grander than a preachy and cheesy farewell article like this. Its purpose is to be a watch dog and a vehicle for the student voice. The Sting offends, but it also defends, it also supports, entertains, creates a permanent record of our time at SPSU. However, it can only be a voice for those students that are willing to take the risk and speak up. It can only defend students when it is given the power and tools to do so.

Well, enough preaching. I'll put away my soap box.

I cannot think of a better honor than being allowed to serve as the Editor-in-Chief of the oldest and most powerful student organization on campus. I thank my staff for all their work, for all their service to the student body, and for standing by me, even when I made stupid mistakes that I'll never admit having made. It is risky business being a Sting staff member. All year long, you have been brave, dedicated, and clever. You have consistently put out an excellent newspaper. I deeply appreciate all your hard work and look forward to watching The Sting evolve. Thank you for the privilege of being your Editor-in-Chief, it was truly my pleasure.

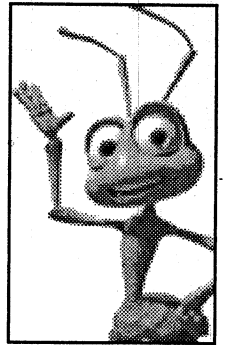

Congratulations! From your staff, friend and the Perio Company (makers of Barbosol shaving cream)



Editor in action. See the marker behind the ear.



# Jawbone of an Ass

MARK CAMPBELL

It was Jan. 26<sup>th</sup>, 2000, at a GOP debate on a cold winter's night in Manchester, New Hampshire. Heating oil prices were up, and the debate moderator decided to put a question to the governor from Texas.

"The Energy Secretary said he would not tap US strategic petroleum reserves in order to drive down prices saying those reserves are for emergencies," said the moderator. Then he asked, "But given the shortages that exist, do you consider this an appropriate time to tap those reserves?"

"No, I don't," responded George W. Bush. "I agree with the energy secretary that the strategic petroleum reserve is meant for a national wartime emergency."

Bush then stated, "What I think the president ought to do is get on the phone with the OPEC cartel and say we expect you to open your spigots. One reason why the price is so high is because the price of crude oil has been driven up. OPEC has gotten its supply act together and it's driving the price, like it did in the past. And the president must jawbone OPEC members to lower the price."

"And if in fact there is collusion amongst Big Oil, he ought to intercede there as well," Bush added.

It's hard to know where to start. Does one mention Ken Lay of

Enron, who sent personal Christmas cards to George? How about the illegally manipulated California electrical energy market? Meeting with good friend Saudi Ambassador Bandar bin Sultan on the Truman balcony of the White House on

Baker Institute at Rice University (it's in Houston) published a white paper in December 2002 for U.S. policy in a post-conflict Iraq – half of its 40-some pages concerned itself with securing, restoring, and improving the Rumaila and Kirkuk

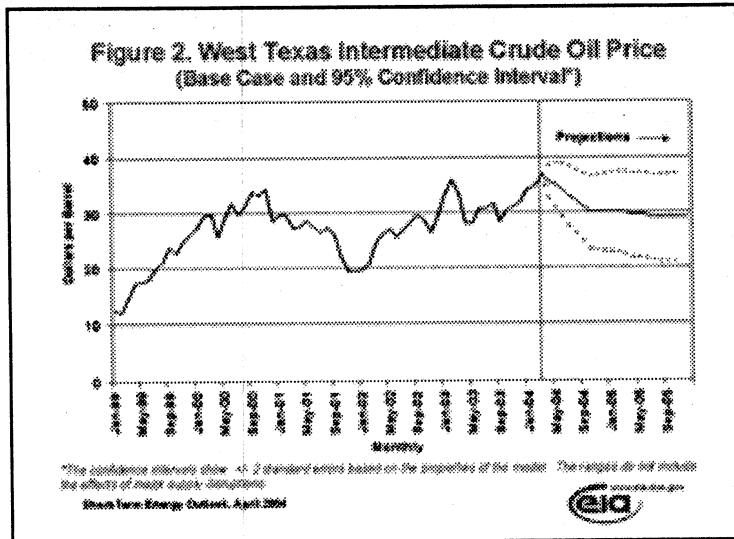

Sept. 14<sup>th</sup>, 2001, not three days after 15 Saudi nationals cost 3,000+ American lives? Or flying a dozen or so bin Ladens out of the U.S. on private jets, while commercial air traffic was halted, and denying the FBI a chance to interrogate them?

Then there's Afghanistan, where the Taliban in the summer of 2001 were road blocks to the Turkmenistan-Afghanistan-Pakistan crude oil pipeline project. And of course Iraq, where the James

oil fields, and self-awarding future drilling concessions.

And of course, now Pulitzer prize-winning journalist Robert Woodward, the White House, and Saudi Ambassador bin Sultan have all come clean. There is no *secret* plan by the Saudi government to increase oil production to drive down prices in a run-up to the November presidential election, thereby boosting Bush's re-election campaign.

And a check of the short-term (18-month) petroleum price outlook published this month by the U. S. Energy Information Administration bears this out. Starting in May, the EIA has crude (West Texas Intermediate grade) falling from about \$38 per barrel now to about \$30 in September. Bear in mind that oil prices rose sharply in 2000 as semi-incumbent Al Gore made a bid for the White House – that was the context for Bush's "jawboning" statement that cold night in New Hampshire.

It is important to note that both the White House and Saudi Arabian Government deny the existence of a *secret* plan to lower petroleum prices in an effort to boost Bush's re-election bid. The plan isn't secret at all – the EIA has published the expected outcome, after all. Both the American and Saudi governments say it is in their best mutual interest to have a vibrant American economy, which depends on low energy prices. Who is going to argue with that?

But here is the rub. Suppose you own a small country that can supply 8.4 million barrels of crude oil per day at a market price of \$34 per barrel, or you can 'open the spigots' and supply 9.6 million Bpd. at \$28 per barrel. What's the difference?

Almost \$17 million dollars – *per day*.

Opening the spigots, and lowering the price, reduces Saudi Arabia's income. While the above scenario isn't exact (it's conservative), that \$17 million per day should be considered a *foreign* campaign contribution from the al Saud family direct to every American on behalf of the Bush-Cheney campaign. For a 90-day run-up to the first Tuesday in November, that's a whopping \$1.5 billion dollar gift.

Of course, George Bush is deeply concerned with foreign influence on the election. He has been highly agitated about MoveOn.org's TV spots critical of his leadership, and argues that they are campaign advertising *paid for by Europeans*. Even his father has

been concerned about such messages. Speaking in March before the National Petrochemical and Refiners Association annual convention, George Bush, Sr., said it was "deeply offensive and contemptible" to hear "elites and intellectuals on the campaign trail" dismiss progress in Iraq.

And of course Bush is concerned that al-Qaeda might conduct terrorist strikes to influence the election – never mind that Americans tend to rally around, not flee from, their president in times of crisis. All one really needs to do to get ahead politically in this country is wrap oneself up in the Stars and Stripes, and another photo-op with beleaguered American firefighters would suit the president well.

Personally, I think that if the al Saud family can figure out that low gasoline prices boost George's re-election chances, then bin Laden is just as smart in figuring that a new terrorist strike in the U.S. would do the very same thing. And I don't think bin Laden likes George very much, so I'm not worrying about terrorism here.

If Woodward is correct, then I think Bush has an excellent chance on keeping the White House. It doesn't seem to matter that we, the American people, were sold a bill of goods (the weapons of mass destruction gambit) for an American conquest of Iraq – over half of us still think Bush is doing a fine job (which is something many Americans would like). His ability, coming this summer, to 'jawbone' the Saudi's into increasing oil production and lowering energy prices – well, it's in the bag, and so is his re-election.

Of course, what happens after the re-election is what really counts. Just like the Department of Defense's discreet calls for volunteers to man the draft boards, the Saudi Arabian government will unlikely find depressed oil prices to their liking. There's no such thing as a free lunch.

And the end game is what should have you quaking like a Philistine before Samson, because with George Bush, you're watching the jawbone of an ass.

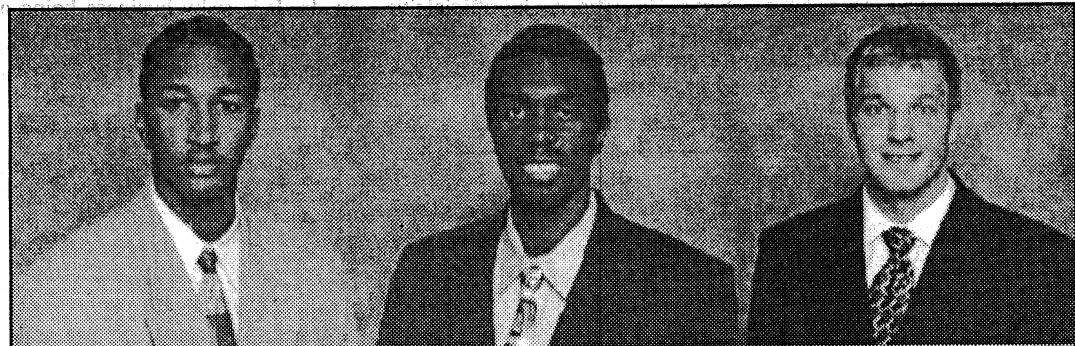

Congratulations to Chris Jackson, Tabius Tate, and Jan Zalud. Jackson and Tate made the GACC All Conference Team, and Zalud made the GACC All Academic Team.



Pure Bliss

The Ultimate Frisbee team has competed in five tournaments this year, and is now 128 of 336 in the nation with a record of 16-11.



SPSU's baseball team ended the season with a record of 12-12 conference and 27-26 overall. They will be playing in the GACC tournament April 23<sup>rd</sup> – 27<sup>th</sup>.

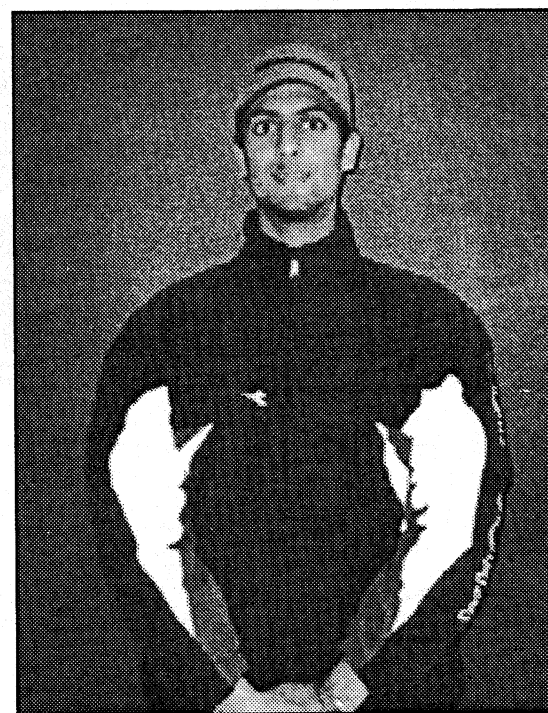

Othman is the #1 player for the SPSU tennis team. He was undefeated this year, and will most likely get national ranking this year.

# Teacher of the Year

HEATHER GIROUX

On Friday, April 2, a luncheon was held to celebrate Dr. Khalid Siddiqi, Chair of the Construction Department, being named the SPSU 2003-2004 Teacher-of-the-Year. When asked how it feels to have this honor bestowed upon him, Dr. Siddiqi replied, "It's a tremendous honor. I feel obligated to work harder in the future, set my standards high, and continue to do even better than before."

The selection of SPSU's Teacher-of-the-Year is a two step process. First, nominations are taken for Outstanding Faculty of the Year. Up to five faculty members can be selected for this honor each year and are chosen by a committee comprised of previous Outstanding Faculty of the Year recipients. From this pool of five, one person is named Teacher-of-the-Year by a committee of President Rossbacher and various other high officials of Southern Poly.

A key element to Dr. Siddiqi's teaching style, mentioned numerous times at this luncheon, is his interaction with his students. Con-

struction student Jeremy Bray affirmed, "Dr. Siddiqi is a very good teacher, very kind, and very helpful. He is considerate of his students; he doesn't want to leave any of them behind. He is more interested in [his] students understanding the material than just covering chapters in a book."

Dr. Siddiqi left me with these closing remarks. "I'm really grateful to the Construction Department faculty for continued support and help in everything I'm able to do. Dean Barnes (our school dean) and the Vice President of Academic Affairs Dr. Hornbeck have continued to guide me in academic and teaching initiatives including organizing fundraisers, improving instructional technology in classrooms, and engagement in faculty development and scholarly activities. I must thank President Rossbacher for acknowledging the above mentioned initiatives taken at the department level and encouraging us all the way through tech fee support, university fee increases, and personal encouragement."

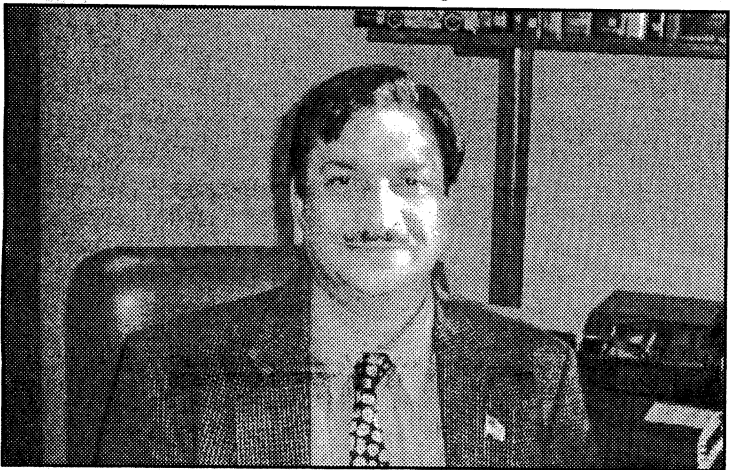

# Rock Climbers Unite

Hey gang, the SPSU rock climbing club is now becoming the SPSU outdoor recreation club; currently we have rock climbing, backpacking and cross-country. We currently have a trip going out to Sand Rock and Little River/Canyon Falls on Saturday the 24<sup>th</sup>. We plan to have half a day of climbing at Sand Rock and the remaining half bouldering and swimming at Little River/Can-

yon Falls. We will be meeting at 8 am at the globe, the cost is 5 dollars (for the gas and other expenses). Also, bring your own lunch.

Please make an effort to RSVP to SPSU-RCC@yahoo.com so that we know the approximate number of people going. On a side note, we will be having the meetings at 5 pm on the first Tuesday of every month

(yes that means we only have one meeting a month). If enough people start showing up to these meetings, food will be provided.

# Steel Bridge

KRYSTALYN NORTON

"We wanna win" said steel bridge coach and SPSU civil engineering

Professor Orlandella and they did win at regional on March 19<sup>th</sup>. No one came close to the SPSU team, not even our rivals at the University of Florida.

The SPSU steel bridge team won first place at USF in Tampa and will compete at nationals in Golden Colorado on May 29<sup>th</sup> against thirty-nine other teams. According to Orlandella the team gave up everyday of their spring break until almost three in the morning to finish the bridge. The steel bridge competition is extremely competitive like many other competitions, but this one is quite different. Of course, to get good enough to win, like any other competition, what is needed is lots of practice and a coach that is never satisfied.

The design process is the first step and the team started on that in

September. During this process, the team must keep the regulations and rules in mind. Many of the requirements changed this year, including increased length of span, decreased length of each section, and a few other requirements. The bridge must meet the dimensions of 25ft long, one span wide, and three support columns.

Then the actual fabrication of the bridge happened in a machine shop in Alpharetta beginning in December. At competition, the team simulates a construction process of an actual bridge. One team member simulates the barge, which holds and connects the pieces together while the rest of the team brings the pieces together. When the

bridge is constructed it is judged on whether or not it meets required dimensions including whether the deflection is less than one inch, appearance, and speed of construction.

With more practice and revision of the design ideas hopefully the SPSU steel bridge team will win the national competition and when they do they will celebrate at the Coors brewery next door to competi-

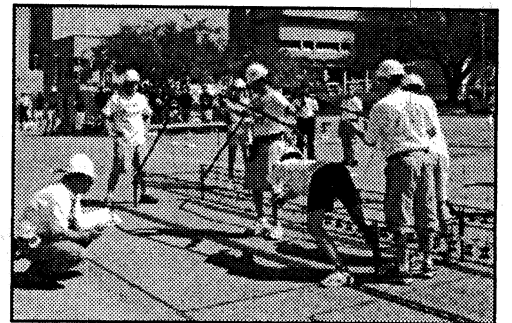

# Concrete Canoe

KRYSTALYN NORTON

The Concrete Canoe is civil engineering competition that takes a lot of time. This year the SPSU team won 5<sup>th</sup> place, which is great because this is the first time in years that SPSU got in the top five. The SPSU team was the only boat that had gunnels, which made this team different. The design of the boat is called a tumble hum design. The team was happy to compete and had a great time. The concrete mix design and the boat design are the major parts of the work involved. The boat is constructed before competition and then raced at the competition. The team is judged on appearance, how well they do in the race, their presentation and a technical paper.

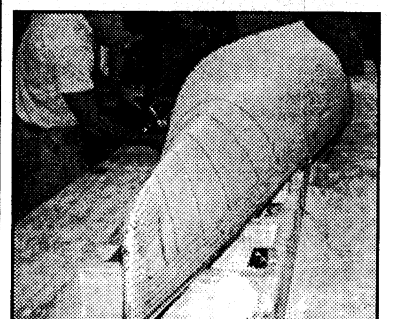

TKE Car Show was Saturday, April 17.

# SGA Budget Story

TONY PEREZ

The Student Government Association approved the budgets for campus organizations for the 2005 fiscal year. A total of 43 organizations are listed to receive funding from SGA. Here is a list of organizations and their allocated budgets, plus SGA's internal budget:

Name Of Organization	Budget
ACM	\$1,000.00
AGC	\$1,000.00
AIAS	\$3,000.00
ASCE	\$5,000.00
Aerial Robotics Team	\$5,000.00
Alpha Phi Alpha	\$1,000.00
Amateur Radio Club	\$1,500.00
Autonomous Submarine Team	\$450.00
Ambassadors	\$2,350.00
Campus Activities Board	\$40,000.00
Caribbean Student Association	\$2,000.00
Cultural Series	\$8,500.00
Forensics Team	\$450.00
Gamma Phi Beta	\$1,000.00
GLBTQ (SAFE)	\$4500.00
GEAR	\$3,000.00
IEEE	\$5,000.00
IIE	\$2,560.00
ISA	\$4,500.00
Japanese Friendship Society	\$2,000.00
Knights of the Realm	\$1,000.00
NOMA	\$2,500.00
NSBE	\$8,000.00
Phi Beta Sigma	\$1,000.00
RHA	\$500.00
Rock Climbing Club	\$450.00
SASA	\$4,000.00
SGA- CWSE	\$32,000.00
SGA- FE	\$2,000.00
SGA- GO	\$20,000.00
SGA- Judiciary	\$2,000.00
SGA- SD	\$51,400.00
Sigma Pi	\$450.00
Soccer Club	\$4,000.00
SHPE	\$1,500.00
Society Of Physics Students	\$450.00
Sparkling Emeralds	\$1,000.00
STING	\$16,164.00
Steel Bridge Team	\$5,000.00
Student Honors Council	\$450.00
Student Center	\$105,053.30
Supermileage Vehicle	\$4,500.00
TKE	\$790.00
University Roundtable	\$5,000.00
Ultimate Frisbee Team	\$2,500.00
WGHR	\$9,000.00
Zeta Phi Beta	\$450.00
SASA (Reserve)	\$0.00
<b>TOTAL Budget:</b>	<b>\$369,917.30</b>

## Incoming SGA:

*President*

**Marvin Broaddus**

*Vice President*

**Kamisha Hammond**

*Secretary/Treasurer*

**Erica Appleby**

*Council Members*

**Brian Barrett**

**Heather Giroux**

**Yolanda Jones**

**Noreen Obanya**

**Nish Patel**

**Zach Phillips**

**Brian Scheiber**

**Demauro Starks**

**Jay Stewart**

**Ryan Thompson**

## Awards:

**SGA Member of the Year:**

**Marvin Broaddus**

**Student of the Year:**

**Fola Adeleye**

**Faculty of the Year:**

**Professor Hahn**

**Staff Member of the Year:**

**Leigh Ann Holton**

**Organization of the Year:**

**CAB ( 2<sup>nd</sup> year in a row)**

# 11<sup>th</sup> Annual Music Midtown

Kenny White

It's that time again; the 11<sup>th</sup> annual Music Midtown is coming up at the end of April. The event that lasts 3 days starts on Friday, April 30<sup>th</sup>, from 5pm-12:30am. It continues on Saturday, May 1<sup>st</sup>, from 2:00pm-12:30 am, and ends on Sunday, May 2<sup>nd</sup> from 2:00pm-10:30pm. 99X, the events main host is sponsoring 2 stages this year. The show includes many local bands as well as well established bands. They include Big Boi of Outkast, Cee-Lo, Default, The Foo Fighters, Fountains of Wayne, Fuel, Jessica Simpson, Jason Mraz, J-Kwon, Joss Stone, Puddle of Mud, REO Speedwagon, Smile Empty Soul, Steve

Miller Band Story of the Year, Switchfoot, Tantric, THE OFF-SPRING, The Strokes, Trapt, Twista, Ween, Wyclef Jean and YoungBloodz. Just to name a few. There are over 80 bands as of now, however more could be added. Tickets can be purchased through Ticketmaster.com or CC.com. The cost is \$40.00 for a one day ticket or \$45.00 for a 3 day pass. For more information you can check out 99X.com, or go directly to MusicMidtown.com. The full band list, directions, and a schedule for all 3 days are posted there for proper planning.



## College Sex Talk 2

A student from the University of Georgia wants to know....

Throughout my college career, I have had a number of dead-end relationships with several guys. It seems things always go fine at first, but within a few weeks it "peeters" out. While at first we had lots to share and talk about, in a matter of just a few weeks, there is nothing left to say to each other. What's wrong? Do I just have really bad luck or what?



Female, Senior

Dr. Caron's Answer:

I'm curious about the relationship you have had with these various guys before you started dating them. Sometimes people think they can meet someone in an evening - fall in love - and that's it...a love relationship has been established. But it needs to be based on some-

thing - such as mutual interests, values. I wonder about your own expectations for a relationship. Clearly the initial meeting is important - but what is the "glue" that holds you together? My motto is

"Start a trend, fall in love with a friend." That way you have a basis on which to judge the person you are now romantically involved with. Also,

there are things you can do to keep the conversation going. Attending plays or guest lectures on campus, or reading articles in the campus newspaper together can certainly provide ideas for conversation. You have to work at any relationship. It doesn't just happen. Best wishes.

Dr. Sandra L. Caron, Ph.D.  
sandy@collegesextalk.com  
www.collegesextalk.com

The editor is finally graduating. The question is, did she earn her degree, or did they give it to her so she would leave? Oh, by the way, she is wearing a pink wig in this picture.



She is going to kill me for publishing this picture, but it is late and I need filler.  
Editor's Note - YEP! See page 14...

## College Sex Talk

A student from the University of Maine wants to know....

How does a woman tactfully tell her partner that she is not satisfied, that he needs to slow down and perhaps take time to do a few more things rather than just take care of himself - especially when he is convinced that he is doing everything well? How do you bring this up?

Female, Senior

Dr. Caron's response:

First of all, I would suggest the conversation take place outside the bedroom. You could begin by saying, "I think our lovemaking is nice, but I'd like to tell you a few things that would make it even better." Or, you may want to ask him what pleases him sexually. Even if he responds that everything is fine, you

could let him know that some things he does for you are fine but he must have some preferences also. By getting him to talk about what he really likes opens up the conversation for you to tell him what you like. It's important to be specific and let him know what turns you on, where, when.... In bed, you may want to show him how you like to be touched. Keep in mind that no one likes to be criticized or made to feel stupid, so try to give your partner positive feedback. By communicating with each other, you will be better able to meet each other's needs.

Dr. Sandra L. Caron, Ph.D.  
sandy@collegesextalk.com  
www.collegesextalk.com



Start by telling him how and where to kiss you.

# EPIC GAMING: Home Alone 2 (Game Boy)

DEVEN GALLO

Howdy! This is Deven "Puppy" Gallo bringing you another game review, this time of one of the most god awful pieces of trash to grace store shelves. The game is Home Alone 2 from THQ. Apparently, these brainless bastards decided the first one was \*good,\* somehow. I believe I got this as a gift when I was a kid, as I'd enjoyed the movie. Back then it didn't seem so bad...

The basic premise is that Kevin caught the wrong plane, and ended up in New York, instead of Paris, where his family went. So, he's

this thing that shoots giant fists, something else I cannot identify, and necklaces to break and trip up enemies (which only do any good in the first level). He can also jump (9 feet into the air) and power slide. The power sliding emits the sound of a train stopping in 0.1 seconds—it's a horrifying squeal the likes of which the world has never known. This lets you dive like a moron under enemies and somehow defeat them this way.

Once you evade the Hotel Staff on the first floor, you

enter an elevator that takes you to random floors (this is some killer programming!) where you fight the insane, pillow-throwing Mega Maid, and the Strangler. This fellow stands in his room, guarding his chalupa he left on the floor. When Kevin advances toward said Chalupa, Strangler launches himself on him and well, strangles him. But it doesn't look like he's strangling, it looks like he's...uh, also, if you jump, even your characteristic 9 foot moon jumps won't save you. He'll launch into the air after you in The Matrix style, and grab you. He is best defeated by shooting him repeatedly with something.

Next you're confronted by Zombie News Dude, back from the

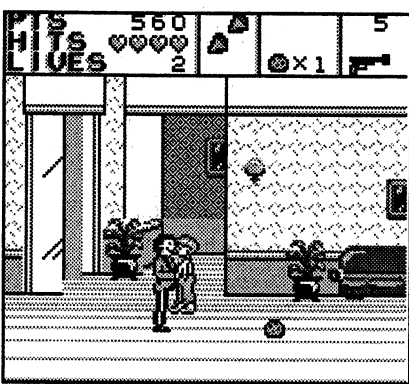

Kevin being 'strangled'. NO MEANS NO!!

grave! Blow him away again and charge forward, evading zucchini-throwing evil chefs, until you have to defeat the Murderous Chef. He'll leap through the air hurling gigantic knives at you.

Power slide under him several times and his clothes fall off and he runs away. This game is just overflowing with disturbing innuendos. He leaves his hat behind, which, for one reason or another, will kill you if you touch it. Damn you, hat!

After clearing that stage, you enter the park, where you're attacked by an endless horde of wooden-club wielding thugs. Some of them also throw cherry bombs. You also need to use...bells?...to jump over the walls. Do it wrong and you're stuck there until you reset. Yeah,

you heard me right: Complete this and you can move on to the Zoo, which was never in the damn movie, full of animals who want you dead as well. Then, the Bat Cave (cave...FULL OF BATS!). Fight through this and you can meet the nice Bird Lady. Too bad she hates you in the game. She sends her hordes of Dive-Bombing Doves to kill you. Eventually, she gives up and gives the Nazi salute to a lad-

der. Climb it to go to the next awful stage, the Goddamn Maze House.

The Goddamn Maze House has a series of doors with a letter on them corresponding to a key with a letter. This is the most mind-numbingly boring level imaginable, and I gave up here. However, you do get to meet some of the best enemies in the game here—the Hovering Criminals! They literally hover up out of the floorboards and wave their arms at you like idiots (god forbid they get out of the floor!) From what I've read, this level is followed by a scene at a Christmas tree of some sort. I don't really understand the continuity here, but maybe that's for the best.

SOUND (2/10): The music for the first level, and the sound effects, are for the most part good. But after that, it degrades into some of the most horrifyingly bad songs you've

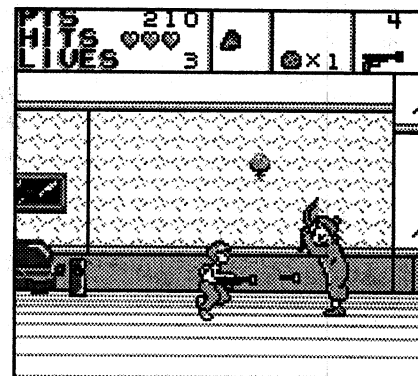

This evil old lady with an umbrella is best subdued with your 9-millimeter—er, dart gun. Then just run past her.

ever heard. The GameBoy can do better than this; the problem here falls solely on THQ's shoulders.

GRAPHICS (1/10): They had potential, they really did. Thing is, the

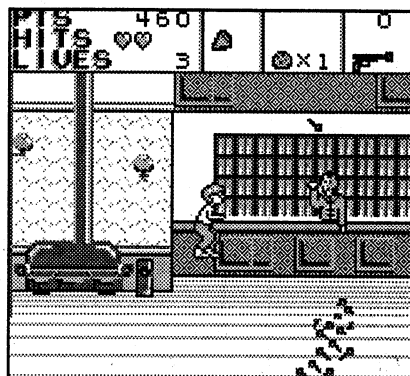

HEIL, MEIN FUHRER UBERLADDER!!

graphic artist (one person, that's all...) just did not give a damn. Kevin's falling animation is the same as his jump. His Ladder Climbing animation flipped horizontally over and over. All the enemies, despite that they are trying to kill you, have huge smiles...the level of detail is not bad, but with all these glaring problems it is hard to give a decent score in this regard.

GAMEPLAY (1/10): It's THQ's 'Home Alone' and 'Rocky and Bullwinkle' and probably others—the exact same engine. The same glitches, the same terrible controls, the same unbearable lag when more than one sprite is onscreen at a time, et cetera. It's another pathetic rehash from THQ, I wasn't expecting anything amazing in this regard, but I was just blown away by the pure suckery of it all.

DIFFICULTY: It's hard to play because it's a writhing mass of glitches. Had it actually been properly tested, improved, and had the creators given a damn, the game wouldn't have been all that hard.

\*OVERALL SCORE: 5/40 (12.5%)\* Home Alone 2 is a terrible piece of shit. Avoid it at all costs.

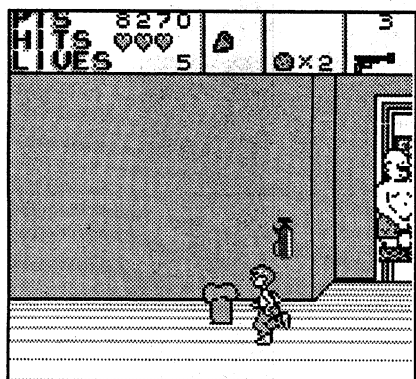

PH34R THE DOOMHAT!!

stuck there and uses his Dad's credit card. He's accused of stealing it, and the hotel employees take it as their solemn duty as responsible citizens to hunt him like a dog and kill him. Only logical, right? So, you're being chased by the Perverted Bellhop, the Creepy Smiling Storekeeper, the Psychotic News Dude, and Senior Strangler, among others. The building's mops, vacuum cleaners, and luggage are also after you. Defeat all of them and subdue the evil News Dude to progress through this floor.

So, how can Kevin defend himself? He can pick up poorly-conceived toy guns, like a suction-cup launcher,

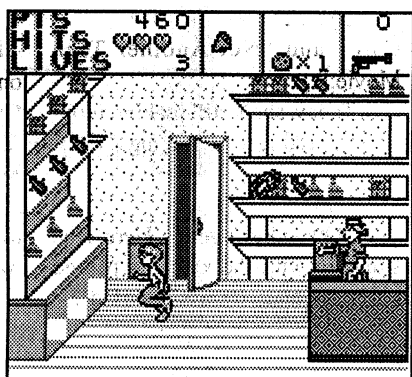

Where you start the game. The smiling Evil Bellhop is an omen of things to come.

## New Novel: Ancient Legacies Unleashed

CJ SHRADER

Alan Beske, a first-time writer from Big Canoe, Georgia, gave me a chance to read over his brand new novel, *Ancient Legacies Unleashed*. I have to admit, the experience was certainly enjoyable.

The novel centers around a college freshman named Ryan Anderson, at fictional Chancellor University right here in Atlanta. When bizarre murders based on stories from Greek mythology begin to occur, Ryan, as well as two of his classmates, Sarah Flemming and Rebecca Chan, consider their history professors as strong suspects. The only question is which one...and why?

The book, like any novel, has certain pros and cons. I'll start by mentioning the cons, since I really want to end on a high note.

Cons: The biggest problem members of SPSU will have this book is identifying with the main character, Ryan Anderson. You see, he's happy to be at school, studies often, and enjoys his classes. Also,

he has two...count 'em, two females pining for his affection. I don't even think there are two females on this campus.

Pros: A point that does make this book very enjoyable is that it's set in Georgia, and, more importantly, around Atlanta and North Georgia. When the characters visit somewhere in Atlanta that you know about, you get to

think to yourself, "Hey, I know where that is." Then, you feel a little spe-

cial in your heart.

Another key point is that the

students are in college. They worry about studying, and exams, and partying. We're in college. We worry about studying, and exams, and partying. Hey, look, we have similarities. Interest ensues.

The biggest seller to me, however, is that

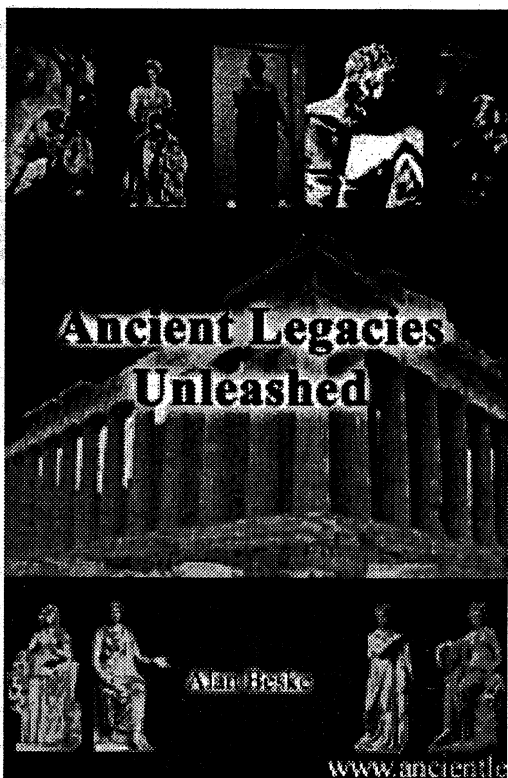

### Ancient Legacies Unleashed

Get your copy of the new mystery novel by Georgia Author, Alan Beske.

Atlanta college students catch serial killer whose crimes are patterned after Greek mythology.

www.ancientlegaciesunleashed.com

the murders in the book are based off of Greek mythology. Be honest with yourself, we're all nerds here. We all like Greek mythology and like to read about it and point out that we know stuff.

Although I'm not going to ruin the story of the novel, I truly don't believe you'll be able to guess the ending. It'll shock you.

*Ancient Legacies Unleashed* is an easy read that I believe most students on campus will enjoy. Students interested in ordering or getting more information on *Ancient Legacies Unleashed* can go to its website, [www.ancientlegaciesunleashed.com](http://www.ancientlegaciesunleashed.com).

Alan Beske is a promising writer and I hope to read his next novel when it comes out. According to the website, his next story is about "a reclusive billionaire who kidnaps some people with specialized talents for the purpose of carrying out a mysterious mission." Sounds good.

# Histories That Matter - Where Are They Now?

CJ SHRADER

Ok, so what you're reading right now is an article I started in the summer and never got around to actually finishing. Some other History that Matters came up or something, I don't remember and you don't care. So, without further ado, I bring you the latest History that Matters, already in progress.

It was 4 am, and my roommate and I had somehow gotten on the topic of celebrities who had simply disappeared without a trace. No, I'm not talking about Amelia Earhart, I'm talking about big bands like Kris Kross, which was what I was curious about, and the cast of Party of Five, which my roommate was curious about.

Actually, those sound like good ideas...let's find out what happened to them.

## Kris Kross

For those of you that were living in a deep dark cave back in the early 90's, I'll start off with a little history of Kris Kross. Kris Kross consisted of two kids from Atlanta, Georgia who sang a little song that made you want to jump jump. They were both 13 when little Chris "Mac Daddy" Kelly and Chris "Daddy Mac" Smith released the song "Jump," which quickly became one of the fastest-selling singles in the US.

Oh, and did I mention that they wore their clothes backwards? Yeah, that was pretty much a staple for them. I have no idea how they went to the bathroom quickly though.

Their song was huge, but then they practically disappeared. What happened to them? Were they destined to go down as another set of "One-Hit Wonders"? Short answer: Yes, yes they were. However, you don't want the short answer, do you? You never do... Let's see how the Mac Daddy and the Daddy Mac were doing after the release of their first CD.

Doing what most bands do if they make it even slightly big, they released another CD in 1993, a year after the release of their original CD, "Totally Crossed Out." The new CD, "Da Bomb," had limited success and didn't come close to reaching the popularity that their earlier CD reached.

Kris Kross laid low until 1996, when they teamed up again to release a brand new CD entitled "YOUNG, RICH, & DANGEROUS." In this new album, they mellowed out their music and changed their style to break away from the childish, backwards clothes image that they'd established back in '92. Once again, this new album didn't do as well as their original. It really didn't make you want to jump jump at all. It made you want to sit down and wonder what happened to the kids we fell in love with.

In related news, a crazed fan with enough gall to call himself "Adam Gardner" began the First

Annual Kris Kross Day the same year that "YOUNG, RICH, & DANGEROUS" was released. He's Canadian, what can you expect? Kris Kross Day has had a huge following, with the 9th "Anal," as he calls it, Kris Kross Day occurring on March 20, 2004. Since the First An-

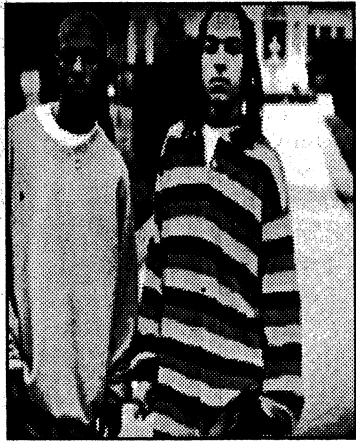

nual Kris Kross Day to the 8th "Anal" Kris Kross Day, there has been a 2000% increase in participants (It started with one person, but he got 20 crazies to do it last year). Maybe SPSU will be there for the 9th "Anal" Kris Kross Day? Not likely.

After that final album, well...I hate to say it, but they totally and utterly \*disappeared\*. I read from one source that one of them became gay, and that's all. I searched the internet until I was at the bottom of Google (I'm sure you know where that is...where the porn starts coming up even though you typed in Mary Kate and Ashley Olsen), and nothing could be found. Nothing. If anyone out there knows, please tell me, 'cause I sure can't find out. E-mail is rshrader@spsu.edu.



## Party of Five

Party of Five, for those who never watched the show (like me), is about five kids trying to cope and be a family after their parents were killed in an automobile accident. The show ran for six seasons, starting in 1994. Naturally, like any teen drama, the kids had to deal with alcoholism, drugs, fitting in, coping with life, sex, pregnancy, responsibility, and flying monkeys.

The five kids are Charlie (Matthew Fox), Bailey (Scott Wolf), Julia (Neve Campbell), Claudia (Lacey Chabert), and Owen Salinger (I'll talk about that in a moment). Let's see where each one went after Party

of Five aired its sixth and final season in the year 2000.

**Matthew Fox** - Matthew Fox went on to star in the TV Series "Haunted" in 2002, where he played Frank Taylor, the main character. He also played a lesser role as the "rock star" in the short film "A Token for Your Thoughts." The thing was 14 minutes long. Movin' on up in the world.

Today, you can see Matthew Fox on VH1's "I Love the 80's." Not bad, Matthew, not bad.

**Scott Wolf** - Odd that the two oldest children both had the last names of dog-like animals. I wonder if they fought often over pieces of raw meat.

Scott Wolf went on to do the voice acting for Scamp in "Lady and the Tramp II: Scamp's Adventure." I never even knew this movie existed. He went on to be in a few other movies that I've never heard of, such as "Jennifer," "Santa Monica Boulevard," "Emmett's Mark," and "Love Thy Neighbor." After that, he went on to the equally bad TV movie, "Picking Up and Dropping Off" in 2003.

Nowadays, he's engaged to Kelley Limp from Real World: New Orleans. Oh, and he was on "Celebrities Uncensored" and "The Sharon Osbourne Show". I bet he misses money.

**Neve Campbell** - If it weren't for the sense of completeness, I wouldn't even add her to this list, since she doesn't really need a "Where are they now." She didn't disappear after "Party of Five". She only got bigger. I mean, come on, she's been in all three "Screams." All three!

Her movie career was actually big \*while\* she was on "Party of Five." Aside from the "Scream" movies, she was also in "The Craft," "Wild Things," did a voice in "Lion King II: Simba's Pride," acted in "Three to Tango" with Matthew Perry, and starred in "Panic." After leaving "Party of Five" in its final season, she went on to many other movies that it's unnecessary to mention them here.

By the way, she used to have a no-nudity clause in her contract. She recently removed that no-nudity clause for a future film. If you're a fan of Neve Campbell naked, then look out for the upcoming films "When Will I Be Loved?," "Churchill: The Hollywood Years," and "A Private War" and maybe you'll get a peak.

**Lacey Chabert** - Ok, so this doesn't actually qualify as "after Party of Five," but I was shocked to find out that Lacey Chabert actually did the voice of Meg Griffin on the show "Family Guy" from 1999 to 2000. Also, she was uncredited for her work. In case you're wondering, the voice of Meg is now done by Mila Kunis.

Lacey Chabert is another person who had a large career during and after "Party of Five." She was also in "Lion King II: Simba's Pride,"

only a day had passed. No clue where they are today.

Owen Salinger #2 (1994-1996) - Played by Brandon and Taylor

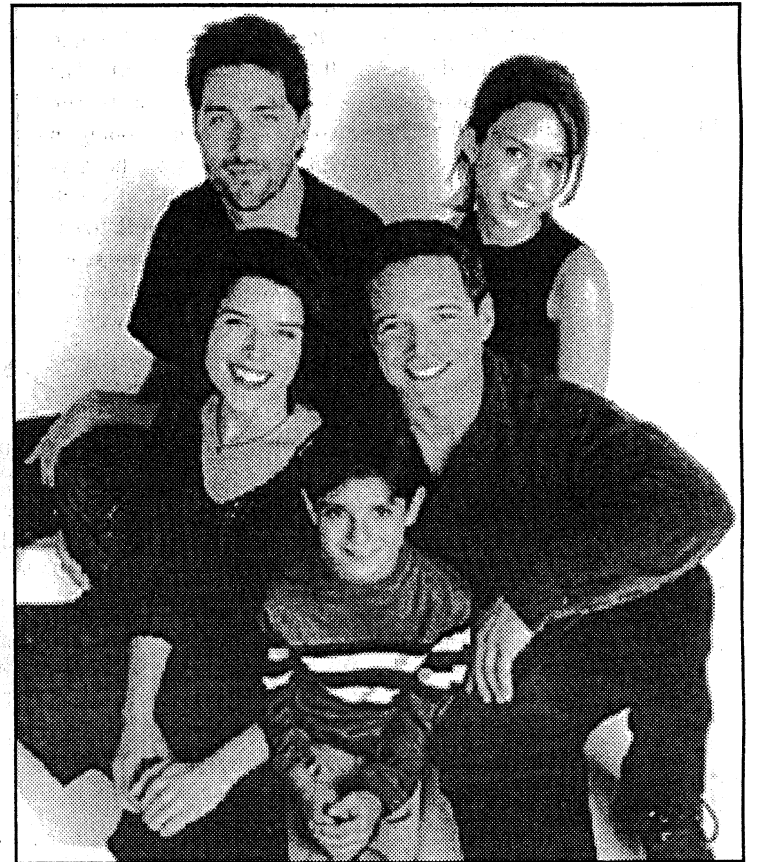

as well as "Anastasia," "Lost in Space," "Wild Thornberry's," "Wild Thornberry's Movie," "Rugrats Go Wild!" and a few other cartoon movies. She must've liked them.

She was also in "Daddy Day Care" and "Not Another Teen Movie."

Today, she's still making movies and making quite a living for herself.

**Owen Salinger** - Here's the situation with the kid who played Owen Salinger. It wasn't one kid...it was seven. Three pairs of twins and another loner. Let's see if we can figure out where they went...

Owen Salinger #1 (Pilot episode) - Played by Alexander and Zachary Ahnert. They played Owen in the pilot episode, which was filmed seven or so months before the "first" episode. Since the "first" episode was filmed seven months after the pilot, but storyline-wise

Porter. Also disappeared.

Owen Salinger #3 (1996-1998) - Played by Andrew and Steven Cavarno. Gone like the Lindbergh baby.

Owen Salinger #4 (1998-2000) - Played by Jacob Smith. He went on to something! Before playing Owen, Jacob was the kid in "Small Soldiers." After playing Owen, Jacob was then in "Dragonfly," "Hansel and Gretel," and "Cheaper by the Dozen." Maybe the lack of a twin kept him from being held back.

All right, that's all for this edition. Have a nice summer break to those leaving, and to those staying...send me e-mails. Wanna find out where some other lost star went? Just send it my way, and I'll find out for ya. The address is rshrader@spsu.edu. See you in the summer.

## China Kitchen

470 Franklin Rd

Marietta

770-429-9020

s. Marietta Pkwy	Franklin	

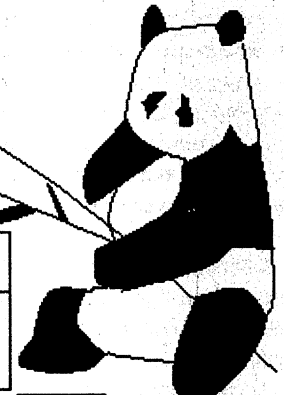

Students:

Daily \$3.75 Specials  
Plus Free Drink with Student ID

# The Worst Movie Review Ever - *Kill Bill: Volume 2*

ANONYMOUSX

Before I even begin this review, allow me to point out the little fact that I arrived exceptionally late at the theater. Why? Because the freakin' Regal Cinema that showed the special press-based sneak preview is located snugly at the intersection of bum-something lane and middle-of-nowhere road. It's almost as if the bastiges that plot out points of interest found the best spot in Georgia to situate a movie theater, then went and placed this one in the EXACT OPPOSITE AREA! So when my hirsute navigator and I finally arrived at the desolate locale, more than a few minutes had passed in the movie. Was it enough to detract from the experience? Read on (or don't, I get paid either way [ed. note: not necessarily]).

*Kill Bill: Volume 2* is the second half of Quentin Tarantino's fantastically gory homage to everything retro and purposely kitschy. Much like the first *Kill Bill*, this film's central theme focuses on the main character, The Bride (played to the hilt by Uma Thurman), and her insatiable urge to enact revenge on the squad of assassins that made an attempt on her life during her wedding. *Volume 2*, picks up where the first movie left off, with The Bride eviscerating her way through the rest of the clan to finally come face-to-face with none

other than the head of the proverbial snake itself: Bill. In a fashion similar to the last two *Matrix* movies and the *Lord of the Rings* series, the volumes of *Bill* were filmed simultaneously, and then broken up into separate movies, thus creating what feels like a long (albeit fun) ride through the mind of an under appreciated director as he strolls down nostalgia lane.

With *Kill Bill: Volume 2* Quentin proves yet again that he can deliver a story deep fried with

character building was completed in the first movie, and the movie is even broken up into easy to digest chapters for those of you with attention spans roughly as short-spanned as a hummingbird on speed. One of the most enjoyable aspects of the movie is the impressive cast Tarantino has chosen to bring his characters to life: David Carradine (as Bill) smirks and snarls with the presence of an actor that has chewed more than his share of the scenery, Daryl Hannah (as Elle

Driver) brings a ruthless intensity and ferocity to the screen that has been unseen in any of her performances since she played the murderous mermaid on *Splash*, and Uma Thurman (as The Bride) manages to appear both vulnerable and venerable as she matches swords, wits, and fists with her myriad foes. From [my] beginning to the end, the movie was riveting and even managed to supercede the first movie in everything except body count and detached limbs. Speaking of the body count, one should notice that this movie has an "R" rating and is quite

graphic (even though the violence is exaggerated), so bringing a five-year old may not be conducive to the tyke's character building. However, at the screening I attended, the row in front of me was littered with

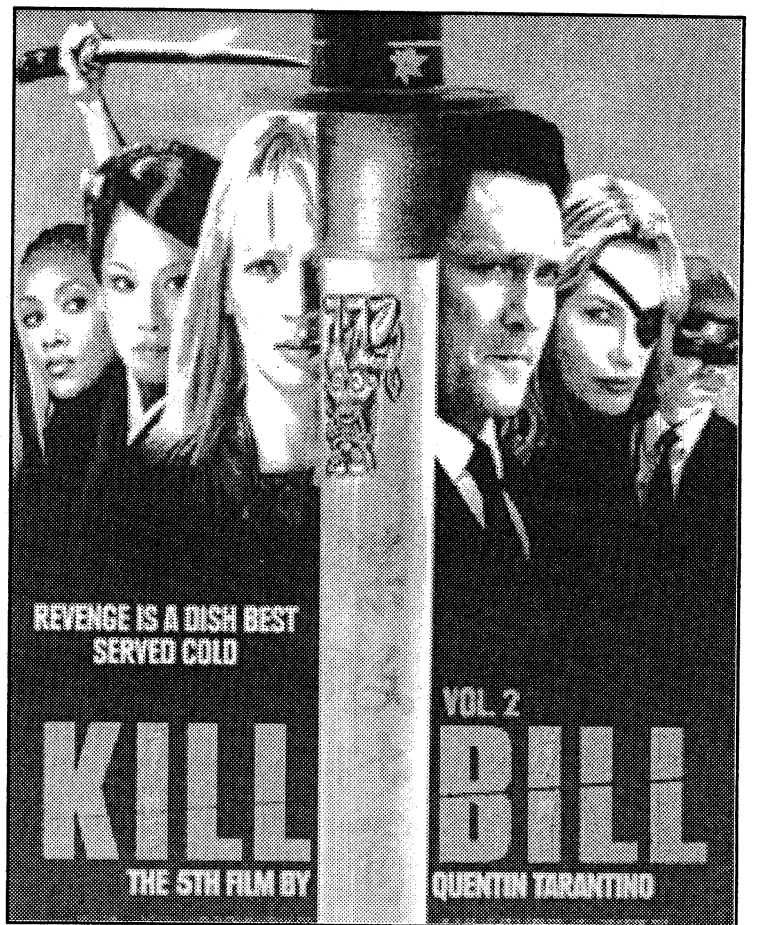
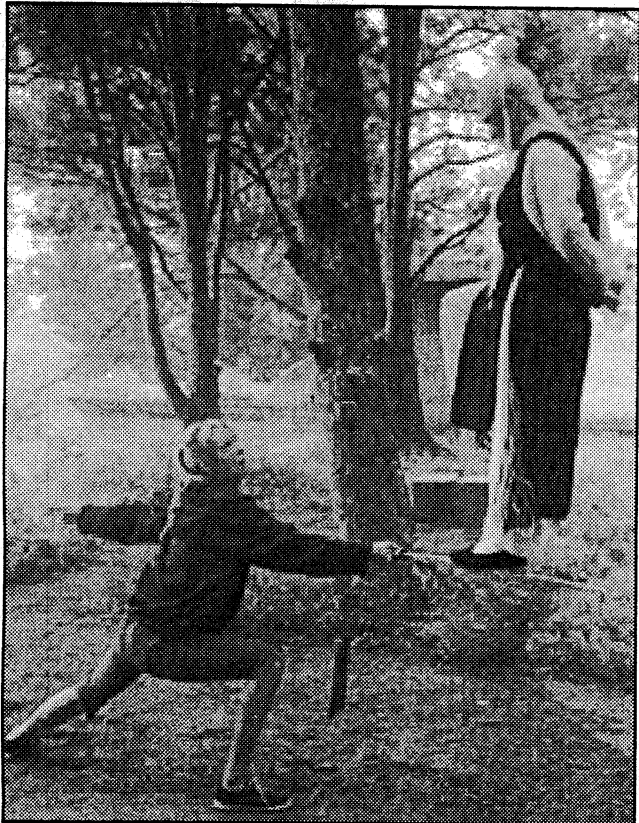

children brought by people that didn't know any better. Each of those kiddies cried out with some exclamation during each one of the movie's more brutal scenes. Don't be one of those people. Leave your kids at home with a nanny, or in the parking lot, or at home with a dude wearing a chainsaw and hockey mask; just don't bring them to this movie!

Those of you that have not seen the first movie need to go out right now and rent it. Yes, now! Drop this paper and go to your local video store (not Blockbuster, those furry bastiges) and rent it. Although *Volume: 1* is not essential to understand the "sequel," it

does help, and it's a good movie anyway so spend the four freakin' dollars. By the time you read this issue, *Kill Bill: Volume 2* will have been out for a while, but if by some chance you haven't seen it, go. You won't be disappointed, and if you are, then blame the Sting Squirrel.

**What's Good:** Terrific sword-play and martial arts, funny and gripping, you'll want to relive Japanese cinema (maybe that isn't a good thing).

**What's Bad:** Feels short (94 minutes), people that are offended by fantasy violence need not apply, Uma's feet.

**The Score:** Four and a half viciously slain henchmen out of five.

## Hooked On Hung

KENNETH "BAM" WHITE

When I set out to write this story, I was intending to make fun of William Hung. If you play on the internet at all, watch TV, read the papers or keep up with American Idol, you have seen William Hung. His rendition of Ricky Martins "She Bangs" was what got him kicked off American Idol. I was doing research on his background, and I found a site that seems to make more sense of what I was planning to write than I can. The site is called sfgate.com. The writer I'm about to quote is Emil Guillermo; he wrote an article entitled "William Hung: Racism or Magic?" I have no intention or interest to prove what it is, and I don't necessarily agree with everything this guy said. He speaks of Hungs appearance on American Idol. "Here was an accented Asian American with bad hair, bad teeth, bad moves and a bad accent. And even though he can't sing, America still loved him."

As I kept reading this bit, it comes to a part where they talk to Shaofan Li, Hung's Civil Engineering professor at UC Berkeley. Its here as Mr. Li is talking that I realize why it is everyone likes Hung. Its

not for his singing, lord knows that sucks. When asked about what makes Hung, well he replies, "Every time he faces the negative, he's oblivious, other people would become insane. He doesn't. He takes it, absorbs it and turns it into a positive. He does it without thinking, naturally. Like Forrest Gump, 'Stupid is as stupid does.' He is such a nice guy and I guess that's why I can't say anything truly bad about him. From what I have seen, he seems to be a great guy, just somewhat on the slow side. Hung was being interviewed on the *Today Show* where he said "I hope people will see me as a serious singer and take my singing seriously."

On a more serious note, this guy couldn't sing to save his life; I like the fact that despite that he still goes on with his singing "career." I think the album has sold over 30,000 copies; although, I can't back that up. I overheard something like that at lunch one day on MTVU News. I'm not really sure who in their right mind would buy this album. I don't know enough words to describe how bad it is. He successfully ruins 11 tracks on his new album, as well as offering "words of gratitude, and

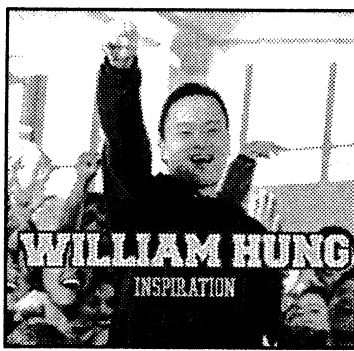

inspirational thoughts on passion, perseverance, and being you. Perhaps the worst song on the album is his remake of the Eagles "Hotel California." Other terrible tracks include "She Bangs", "Bailamos", "I Believe I Can Fly" (which is the second worst track on the album), "Can You Feel The Love Tonight", "Rocket Man", "Circle of Life", "Y.M.C.A." and "Shake Your Bon-Bon". All these songs are terrible and I don't really recommend them at all. I found that my jaw hurts, just as much, if not more, than my ears, after listening to his noise. One day I called Toys R Us and, at that point, I thought I had heard the worst music ever while on hold. I was wrong. I give William Hungs "Inspiration" "3 thumbs down".

## The Sting's New Editor-in-Chief Karen Ass\*ay

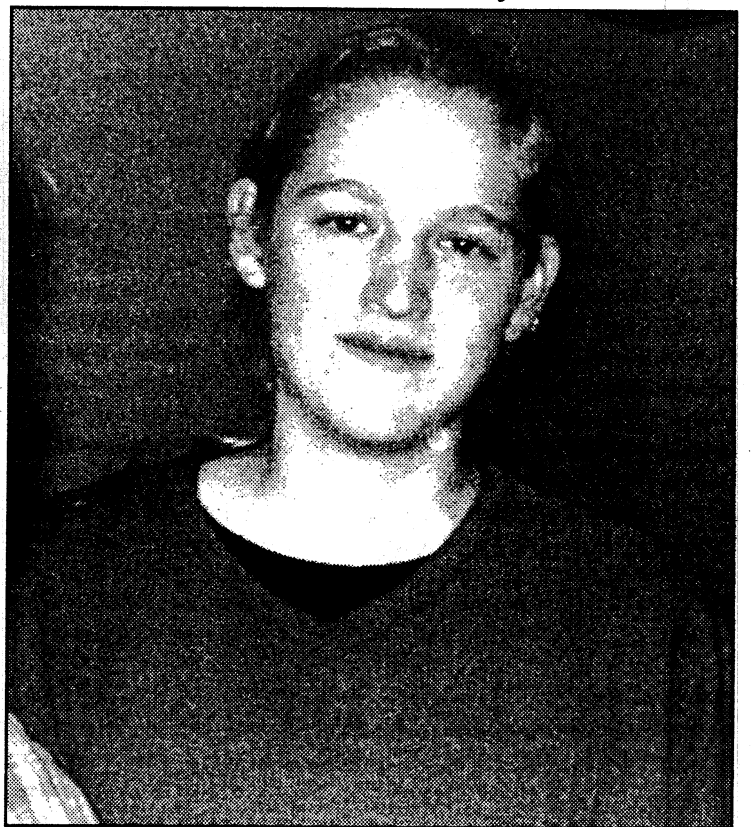

A blonde saw a "¢" on her computer screen and asked another blonde, "How do you do that?" She responded... "Simple, turn the keyboard upside down!"

Good luck keeping the keyboards right side up in *The Sting* office, blondie! Seriously, you're gonna do an AWESOME job! - Miranda

This is the Tom Green page  
 It's not the Green Tom page  
 This is my favorite page  
 Because it is my page  
 It's the Tom Green page  
 Mwhaaaaaooooooooo

## Why Having A Girlfriend Is Like Having A Job

**TOM GREEN**

There are reasons why having a girlfriend is like having a job. First of all, to get one you must go through the interview process. The normal questions of "What is your name? Where did you go to school? How did you do? What are you studying? Did you graduate? Where did you use to work? What did you do there? Are there any qualities that you have that would be useful to this position? Who are some personal references? And can they be contacted?" You know the normal questions in an interview.

And then once you have it, you have to check in everyday. And if you can't make it you have to call in. And you have to decide how much you want out of it because

that determines how much work you are going to put in. I mean, if you decide to only work part time then you aren't going to get anything.

But if you work fulltime then you get benefits. And if you work over time then you will normally get extra or something special. And the more you put into them the more satisfied you will be. If you piss off the boss then you are in for some rough times. If you hang in for the long haul instead of moving on then that is when you really start to reap the benefits.

But if you don't do a good job then they might lay you off and you will be out on the streets. See, there are so many similarities between having a girlfriend and having a job.

## Green Review

**TOM GREEN**

*His Dark Materials Saga*  
 By: Phillip Pullman

*His Dark Materials Saga* includes the books *The Golden Compass*, *The Subtle Knife*, and *The Amber Spyglass*. With shape changing familiars, flying witches, and armored bears the adventures that Lyra has are very exciting at a non-stop pace. There is no book like this that can be compared too. It is that unique. It is a must read.

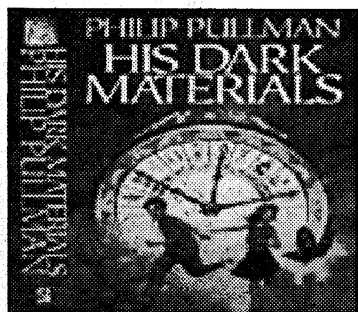

*The Obsidian Chronicles*  
 By: Lawrence Watt-Evans

*The Obsidian Chronicles* include *Dragon Weather*, *Dragon Society*, and *Dragon Venom*. A boy's village and everyone he knows is killed by a dragon attack. He is sold into slavery from which he escapes and goes on to seek revenge against the people that sold him into slavery, and, even more, to seek vengeance against the dragons themselves. A must read.

*Dawn of the Dead*

This was an awesome movie. It starts out rather nice, but when the first zombie attacks, you are like holy shit. Ahhhh! Then, it quickly becomes apparent that it is suppose to be funny when this guy gets hit by an ambulance, and

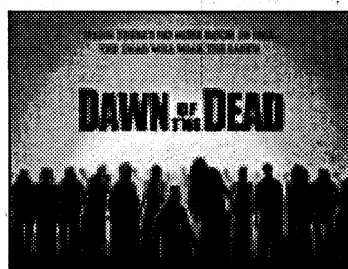

it doesn't stop. Then when one zombie is chasing the main character and gets distracted and goes to attack someone else, and the woman just screams. It was funny. This was all within the first 10 minutes of the movie. It gets better from there. I suggest you watch it all the way through the credits.

*Hidalgo*

Don't bother seeing it in the theater. It is a good movie, but it doesn't need the big screen. It is about an American mustang participating in a horse race in Arabian Desert. They tried to advertise this as an adventure movie, but it's not. Well, not to the ex-

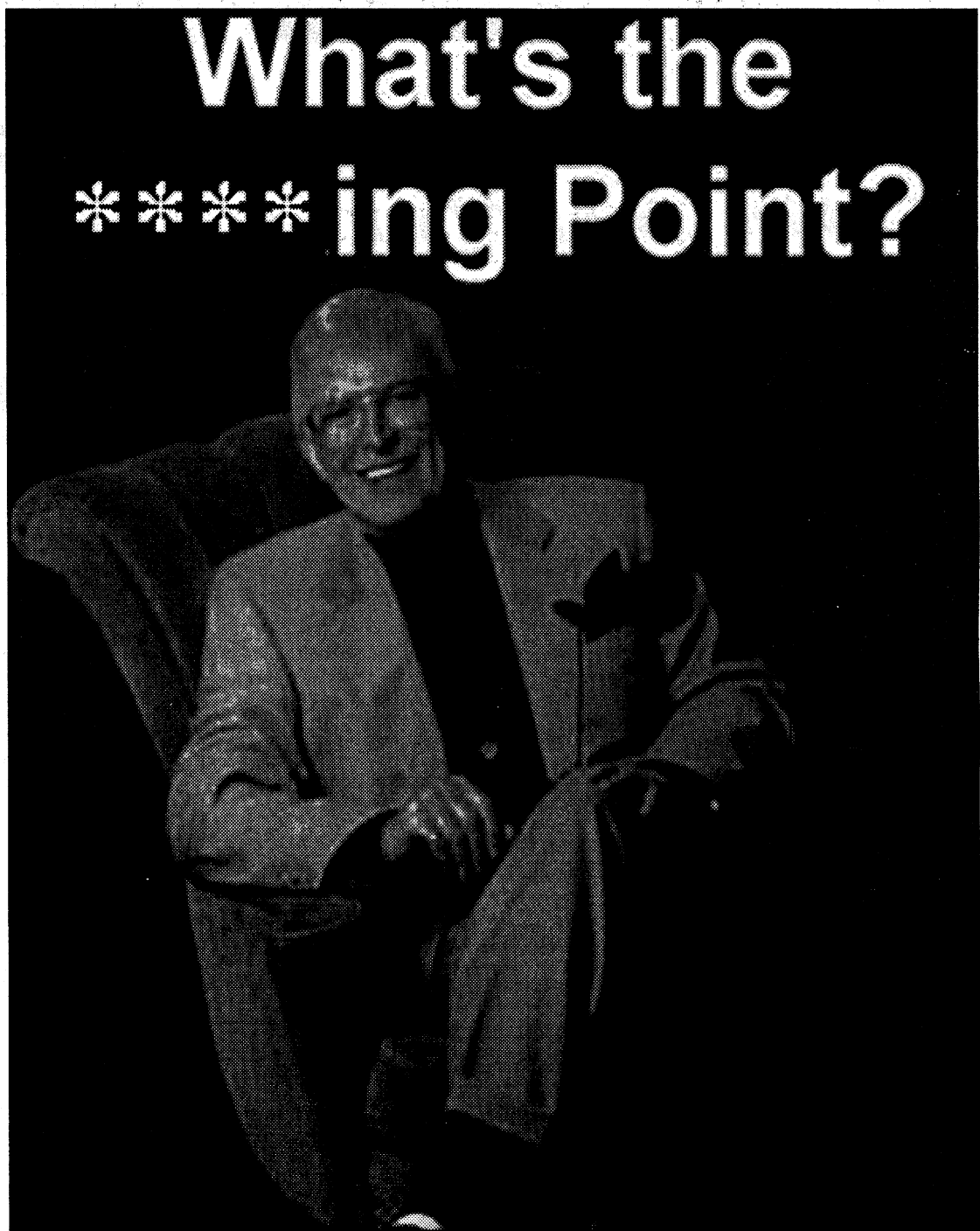

Well, I think that about sums the page up

## My Shit is Green!

**TOM GREEN**

A couple weeks ago an acquaintance and I had obtained several boxes of blueberry Fruit by the Foot for free because they were being thrown since they were nearing their expiration date. Well, I have been eating about a box a day since we got them. The first day there were

no affects so I ate more of them. Well, the next day I see that my shit is green. I started to freak because it's not normal for your shit to be green. Then I remember the blueberry Fruit by the Foot. And the mystery behind my green shit was solved.

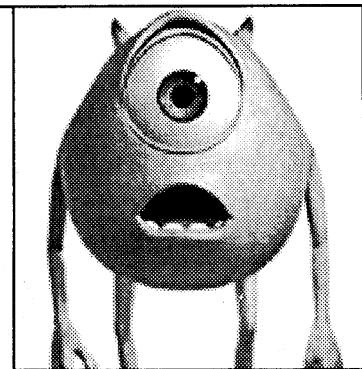

Exactly

tent that it was hyped to be. It was still a good movie, though.

*How to Give Her Absolute Pleasure*  
 By: Lou Paget

OK, guys and girls. As long as you have some idea about how sex and relationships work don't bother reading this book. It, basically, says that you have to take your time and spend a long time doing every as-

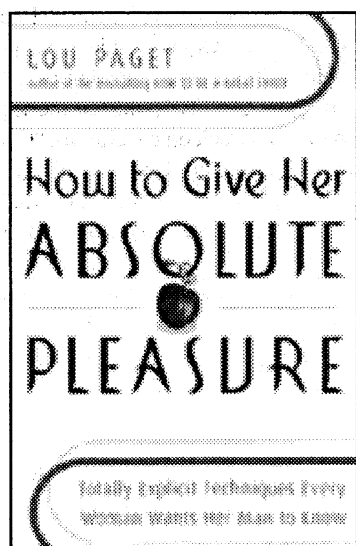

Does absolute pleasure corrupt absolutely?

pect to give her absolute pleasure. Yes, I did read the book. That is how I know it sucks.

If you don't know that you have to be nice to the girl when you see her and do things that she likes and make sure to be a gentleman, then you might need to read this book. It goes into detail about how to do things like that.

It also gives pointers on how to have sex. It goes into excruciating detail about how to give a woman oral sex. The simple advice that it gave was writing the letters of the alphabet with your tongue, and to practice by eating Jello or pudding out of a single serving container with just your tongue.

It also said that when you are having intercourse, if she moves you into a different position; don't go back to the old one. They want you right where you are, and once you are in, stay in.

That is the summary of the book. Like I said, if you don't know the basics, then maybe you should read this book. I guess it is ok, if you don't know what's going on. Otherwise it just sucks.

*Snow Drop*

I was given this game as a joke, but I played it anyway. It is a very boring game. The text is boring, and there is really no plot to speak of. The outtakes are still frames, instead of movies and the music isn't that good. The sound effects are decent, I guess. The animation quality is sub par, so for a hentai game, this isn't a good one. Well, this is the first one I played, but still I don't think it would be considered a good one.



Her man didn't read the book

# Student Questions

1.) What do you think about Bush being gay?

2.) Who would win in ariel combat? A crocodile with wings or a shark with a jetpack?

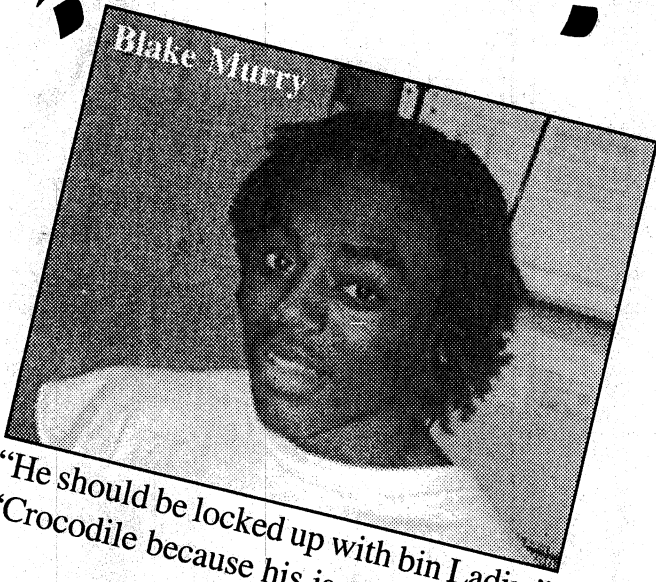

Blake Murry

"He should be locked up with bin Ladin."  
"Crocodile because his jaw is stronger."

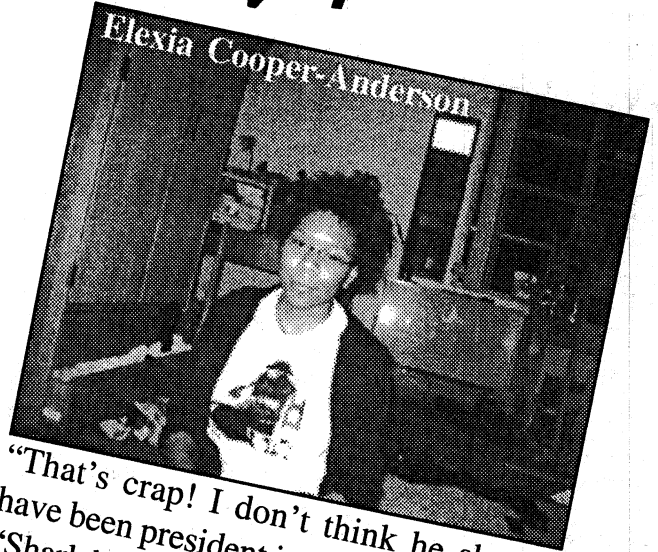

Elexia Cooper-Anderson

"That's crap! I don't think he should have been president in the first place!"  
"Shark because technology overrides all that natural stuff."

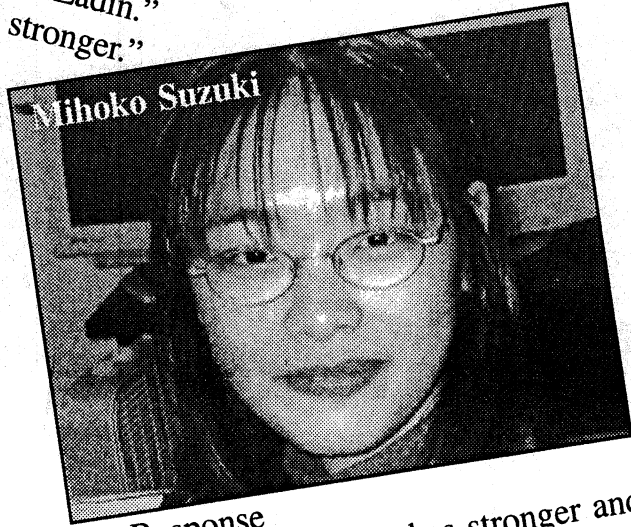

Mihoko Suzuki

No Response  
"Crocodile because he has stronger and he has sharp teeth."



Sarah Sucharski

"What was done was done, he only had a certain amount of control. He is handling it as well as he can now."  
"Shark because he has sharp teeth."

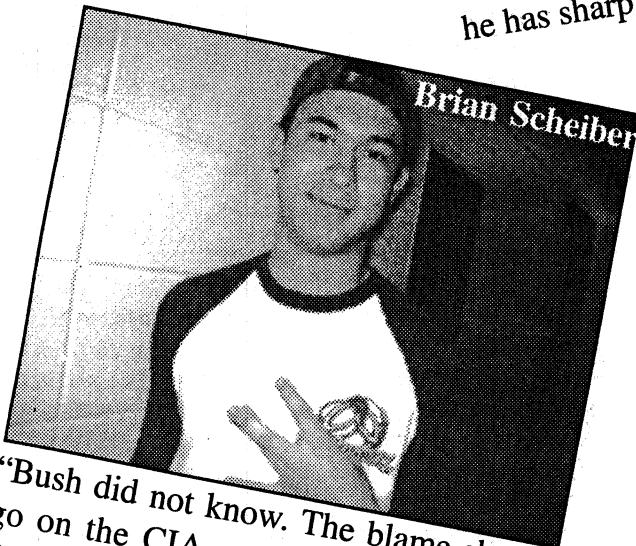

Brian Scheiber

"Bush did not know. The blame should go on the CIA or Cabinet if anybody. Bush made the best decision he could with the information provided."  
"The crocodile because he's more versatile."

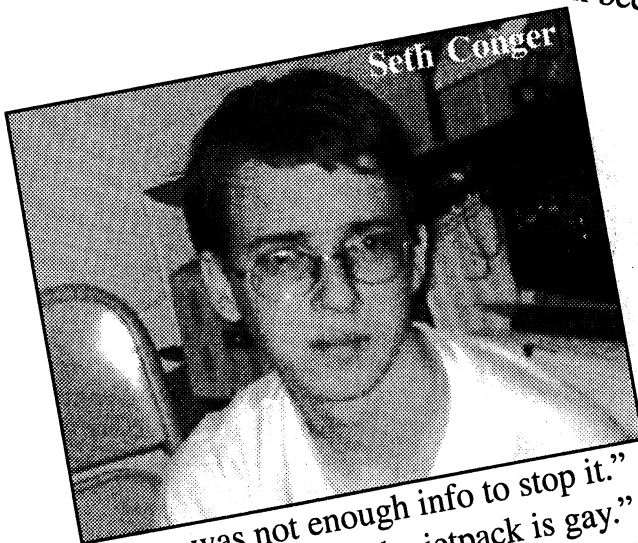

Seth Conger

"There was not enough info to stop it."  
"Crocodile because the jetpack is gay."

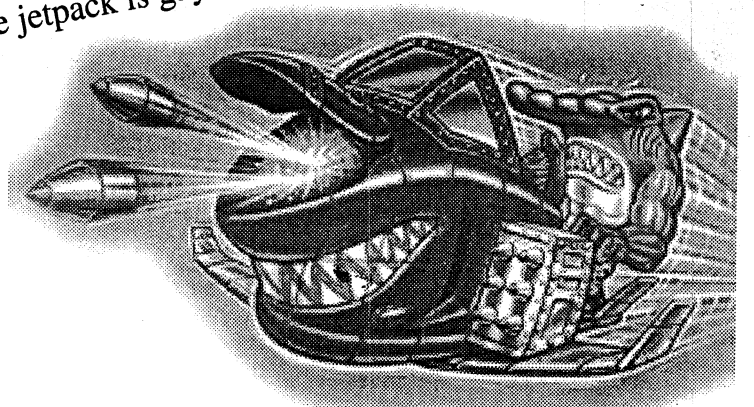
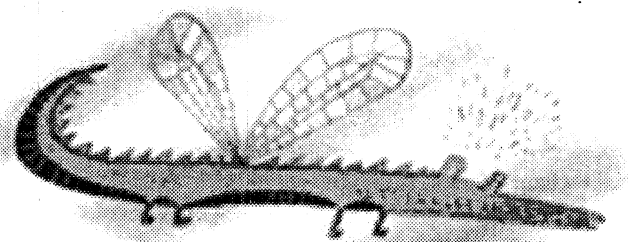

[The question about Bush was not the question that was asked, but we forgot the original question. Please don't be offended. It is meant as a joke and nothing more.]